



PARTS CATALOG

of the

Seabee

A PRODUCT OF **REPUBLIC AVIATION**

Makers of the Mighty Thunderbolt

Editor's Note: This Parts Catalog has been reproduced from the original Republic Parts Catalog. Obviously, most of the information is obsolete; the pictures are accurate and "up-to-date". If nothing else, this gives you a clearer picture as to what is underneath that beautiful facade. You must use your best judgment as to how you will use this catalog. The editor takes no responsibility for its accuracy.

HULL	Click Here
CABIN DOORS AND WINDOWS	Click Here
CABIN FURNISHINGS	Click Here
CABIN FURNISHINGS (Page 2)	Click Here
LEFT WING	Click Here
RIGHT WING	Click Here
PILOT AND COPILOT CONTROL WHEELS	Click Here
RUDDER AND BRAKE PEDALS	Click Here
CONTROL COMPONENTS	Click Here
CONTROL COMPONENTS	Click Here
HYDRAULIC SYSTEM	Click Here
LANDING GEAR	Click Here
TAIL WHEEL	Click Here
EMPENNAGE	Click Here
ENGINE AND PROPELLER	Click Here
ENGINE MOUNT	Click Here
ENGINE COWL	Click Here
ENGINE AND PROPELLER CONTROLS	Click Here
FUEL SYSTEM COMPONENTS	Click Here
INDUCTION SYSTEM	Click Here
ENGINE AIR HOUSING	Click Here
INSTRUMENT PANELS	Click Here
FLIGHT AND ENGINE INSTRUMENTS	Click Here
ELECTRICAL EQUIPMENT	Click Here
RADIO	Click Here

INTRODUCTION

This Catalog:

The Seabee Parts Catalog illustrates and lists, by catalog item numbers, all spare parts for the Seabee Amphibian (Model RC-3) manufactured by Republic Aviation Corporation, Farmingdale, Long Island, N.Y. Each catalog item number is accompanied by an illustration to facilitate identity. Indented item names signify procurable sub-assemblies of items on the first column.

Catalog Numbers:

The numbers, which appear in this catalog, are not manufacturing part numbers, but are "spare item numbers". Designed as a kit each spare item contains, in addition to the basic part or assembly, all of the attaching hardware and materials necessary to effect immediate installation on your Seabee.

Ordering:

When ordering, state the quantity and list the parts by catalog item number and name. Make certain that the correct number is given. Left and right hand parts are listed and illustrated separately. Do not order attaching hardware since this is automatically included with each spare item.

Prices:

This first issue of the Seabee Parts Catalog has been rushed to completion to assist you in ordering the spare items you may need for your Seabee. Prices are not yet available, but as soon as determined, the final priced issue will be published.

Shipping:

Each spare item that you order will be individually packaged. The package will contain the basic part plus attaching hardware. Each package will be identified by the spare item number.

Shipment will be made by the most direct method unless otherwise specified.

HULL

<u>NUMBER</u>	<u>PART NAME</u>
1001	<u>HULL-COMplete WITH ELECTRIC WIRING, FUEL AND HYDRAULIC LINES, CONTROLS, AND LANDING GEAR MECHANISM</u>
1002	<u>Hull Assembly-Forward (from Nose to Step)</u>
1357	BATTERY BOX ASSEMBLY.....
1014	Cover-Battery Box.....
1006	KEEL AND BOTTOM BOW SKIN ASSEMBLY.....
1003	Skin-Right Hand Bottom Bow.....
1004	Skin-Left Hand Bottom Bow.....
1005	Keel-Forward Section.....
1361	Plug-Keel Drain (Not illustrated).....
1007	BOTTOM ASSEMBLY-INTERMEDIATE HULL.....
1008	SKIN-LEFT HAND HULL BOW.....
1009	SKIN-RIGHT HAND HULL BOW.....
1010	FLOOR ASSEMBLY-FORWARD CABIN (SHIPS 1 TO 125).....
1012	Door-Deck Access.....
1013	Plug Button-Cabin Floor Forward.....
1011	DOOR-LANDING GEAR ACCESS.....
1417	COVER-ANCHOR STOWAGE HATCH.....
1015	STEP-LEFT HAND PASSENGER.....
1016	STEP-RIGHT HAND PASSENGER.....
1017	<u>Hull Assembly-Aft (from Step to Tail)</u>
1018	COVER-HULL HANDHOLE.....
1019	KELL-AFT SECTION.....
1020	Hull Boom-(from Tail Wheel splice to Tail).....
1021	<u>KIT-COVER (INCLUDING HANDHOLE COVERS AND ACCESS DOORS)</u> <u>(NOT ILLUSTRATED)</u>

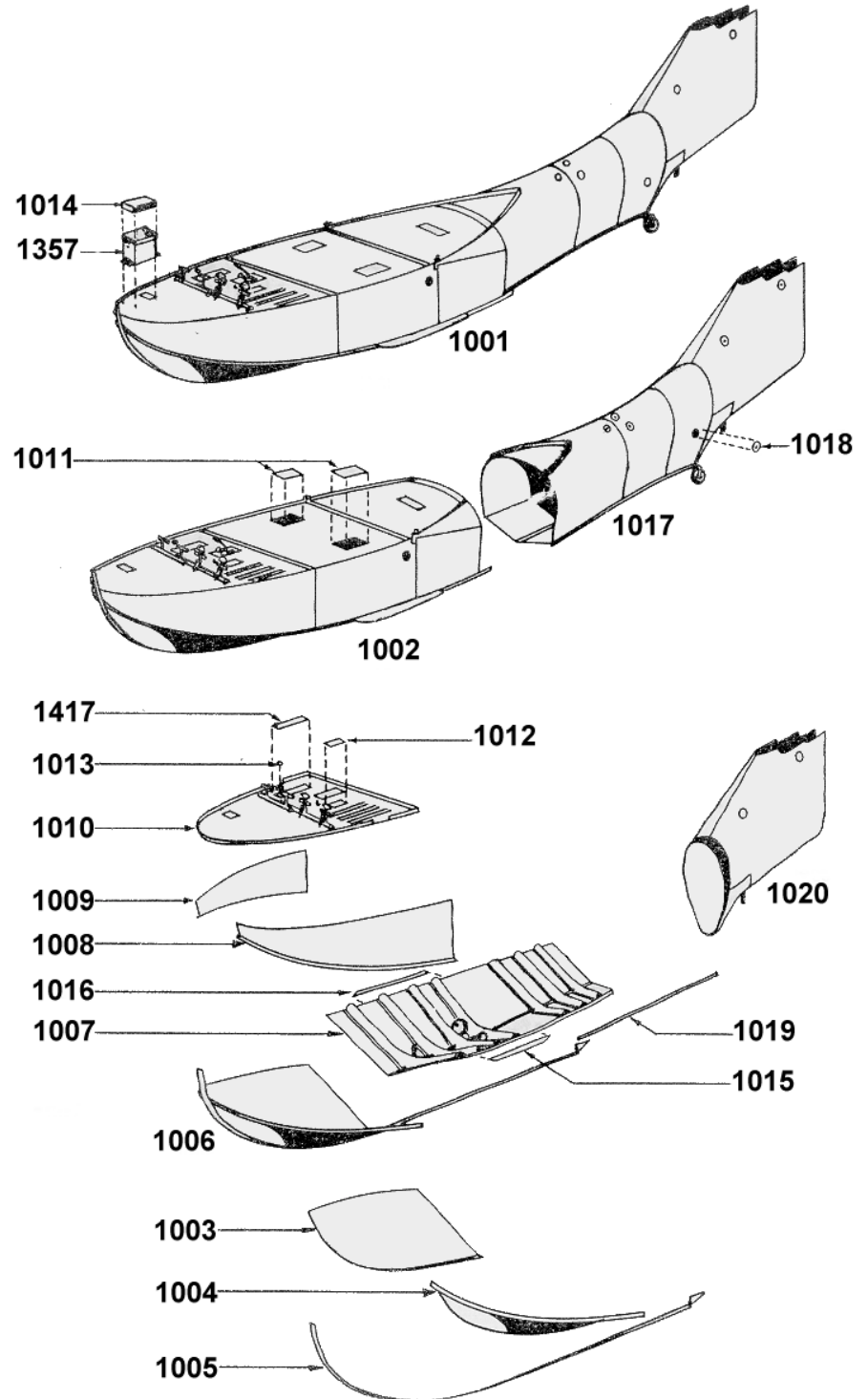

CABIN DOORS AND WINDOWS

<u>NUMBER</u>	<u>PART NAME</u>
1022	<u>DOOR-LEFT HAND CABIN WITH WINDOW AND LOCK</u>
1023	<u>Window-Left Hand Cabin Door with Clearview Panel and Rubber Molding</u>
1190	<u>PANEL-LEFT HAND CABIN DOOR CLEARVIEW</u>
1026	<u>MOLDING-LEFT HAND CABIN DOOR WINDOW RUBBER</u>
1027	<u>Lock-Left Hand Cabin Door with Handles, Toggle and Mechanism; Key</u> ...
1029	<u>Stop-Left Hand Cabin Door Sliding</u>
1028	<u>PLATE-LEFT HAND CABIN DOOR STRIKER</u>
1030	<u>DOOR-RIGHT HAND CABIN WITH WINDOW AND LOCK</u>
1031	<u>Window-Right Hand Cabin Door with Rubber Molding</u>
1032	<u>Lock-Right Hand Cabin Door with Handles, Toggle and mechanism</u>
1034	<u>Stop-Right Hand Cabin Door Sliding</u>
1028	<u>PLATE-RIGHT HAND CABIN DOOR STRIKER</u>
1035	<u>DOOR-CABIN BOW WITH WINDOW AND LOCK</u>
1036	<u>Windshield-Cabin Bow Door with Rubber Molding</u>
1037	<u>MOLDING-CABIN BOW DOOR WINDSHIELD RUBBER</u>
1038	<u>Lock-Cabin Bow Door with Handles, Toggle and Mechanism; Key</u>
1202	<u>Stop-Cabin Bow Door</u>
1039	<u>PLATE-CABIN BOW DOOR STRIKER</u>
1040	<u>WINDSHIELD-LEFT HAND CABIN BOW WITH RUBBER MOLDING</u>
1041	<u>Molding-Left Hand Cabin Bow Windshield Rubber</u>
1042	<u>WINDOW-CABIN CROWN WITH VENTILATORS AND RUBBER MOLDING</u> ..
1024	<u>Ventilator-Cabin Crown Window Rubber</u>
1043	<u>Molding-Cabin Crown Window Rubber</u>
1416	<u>Gasket-Cabin Crown Window Ventilator</u>
1044	<u>WINDOW-LEFT HAND CABIN AFT WITH RUBBER MOLDING</u>
1024	<u>Ventilator-Left And Cabin Aft Window</u>
1046	<u>Molding-Cabin Rear Window Rubber</u>
1416	<u>Gasket-Left Hand Cabin Aft Window Ventilator</u>
1045	<u>WINDOW-RIGHT HAND CABIN AFT, WITH RUBBER MOLDING</u>
1024	<u>Ventilator-Right Hand Cabin Aft Window</u>
1416	<u>Gasket-Right Hand Cabin Aft Window Ventilator</u>
1047	<u>SKIN-LEFT HAND CABIN BOW</u>
1048	<u>SKIN-RIGHT HAND CABIN BOW</u>
1049	<u>SKIN-CENTER CABIN BOW</u>

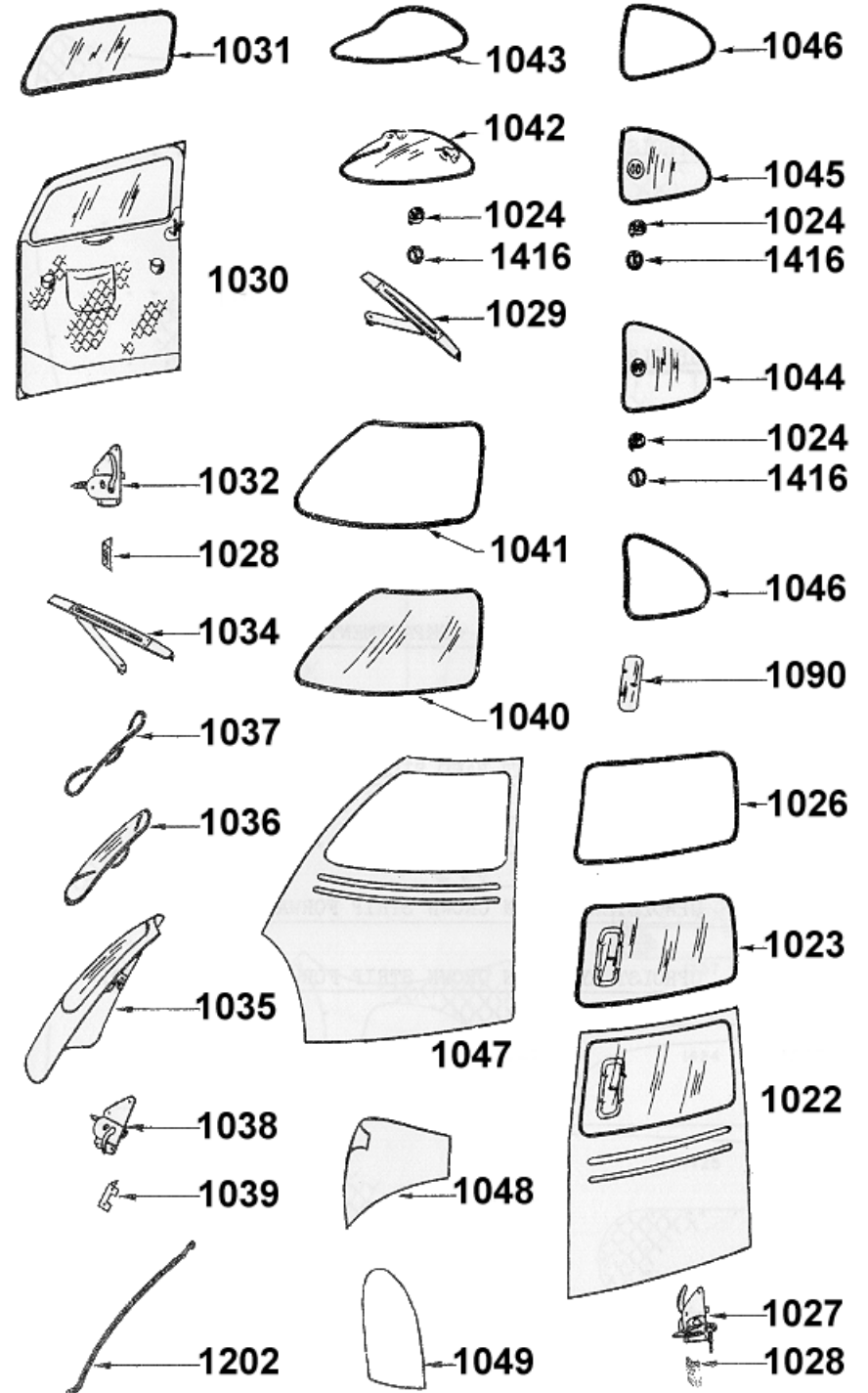

CABIN FURNISHINGS

<u>NUMBER</u>	<u>PART NAME</u>
1334	<u>UPHOLSTERY-LEFT HAND REAR SIDE PANEL</u>
1335	<u>UPHOLSTERY-RIGHT HAND REAR SIDE PANEL</u>
1337	<u>UPHOLSTERY-BOW PANEL</u>
1338	<u>UPHOLSTERY-HEAD LINER</u>
1339	<u>UPHOLSTERY-BAGGAGE COMPARTMENT BULKHEAD</u>
1340	<u>UPHOLSTERY-FIREWALL</u>
1341	<u>UPHOLSTERY-DOOR POST LEFT HAND</u>
1342	<u>UPHOLSTERY-BAGGAGE COMPARTMENT DOOR</u>
1358	<u>UPHOLSTERY-LEFT HAND SIDE DOOR</u>
1359	<u>UPHOLSTERY-RIGHT HAND SIDE DOOR</u>
1360	<u>UPHOLSTERY-BOW DOOR</u>
1424	<u>UPHOLSTERY-CABIN CROWN STRIP FORWARD LEFT HAND</u>
1425	<u>UPHOLSTERY-CABIN CROWN STRIP FORWARD RIGHT HAND</u>

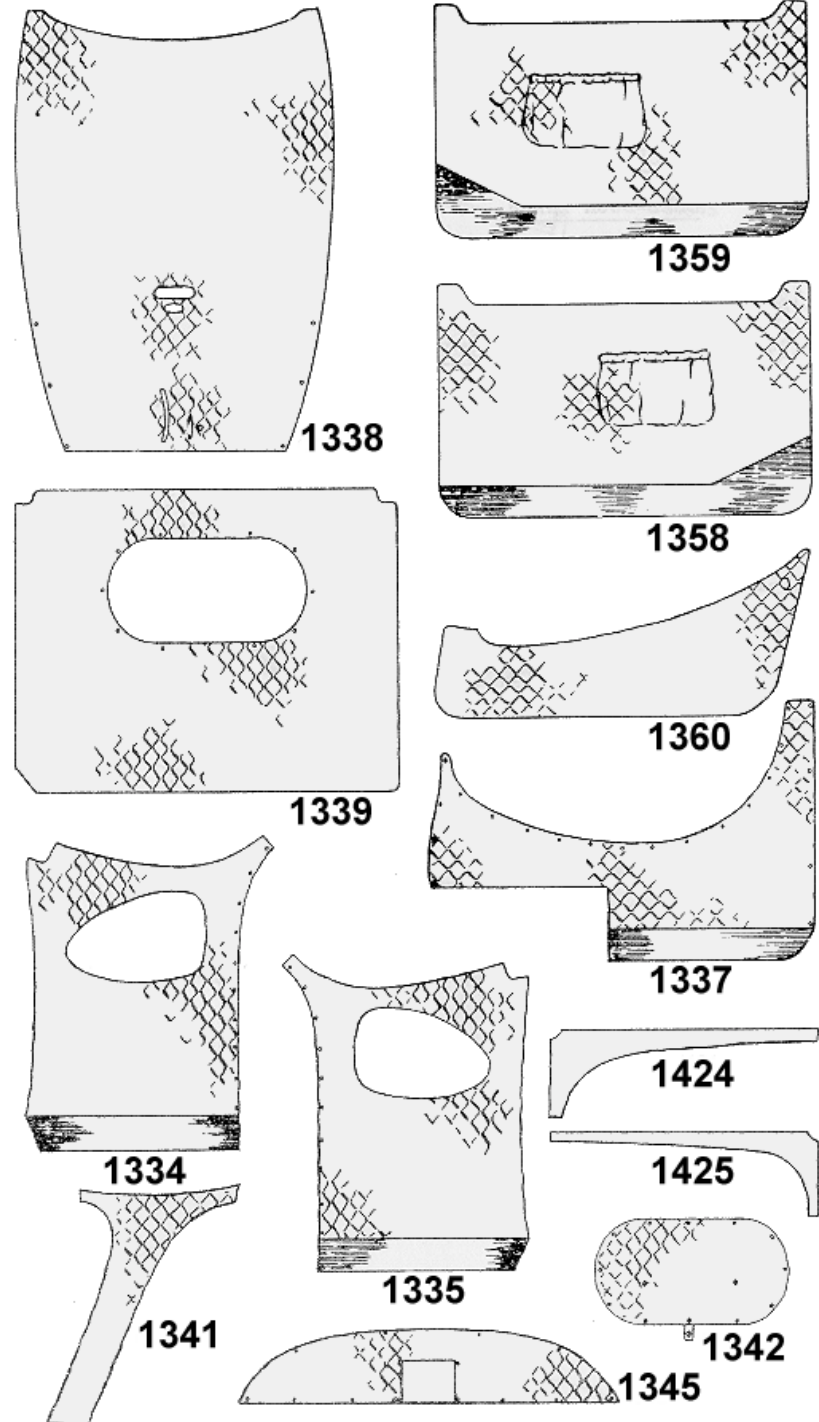

CABIN FURNISHINGS (CONT.)

<u>NUMBER</u>	<u>PART NAME</u>
1336	<u>UPHOLSTERY-FLOOR MAT</u>
1343	<u>SEAL-DOOR INNER</u>
1344	<u>PIN-BOW DOOR HINGE</u>
1345	<u>PIN-SIDE DOOR HINGE</u>
1346	<u>DOOR ASSEMBLY-BAGGAGE COMPARTMENT</u>
1347	<u>STRAP INSTALLATION-FRONT ASSIST</u>
1348	<u>STRAP INSTALLATION-REAR ASSIST</u>
1349	<u>TRACK-LEFT HAND FRONT SEAT</u>
1350	<u>TRACK-RIGHT HADN FRONT SEAT</u>
1351	<u>SLING-BAGGAGE</u>
1352	<u>FRAME ASSEMBLY-FRONT SEAT</u>
1353	<u>FRAME ASSEMBLY-REAR SEAT</u>
1354	<u>SEAT BACK-FRONT</u>
1413	<u>Bladder, Seat Back</u>
1355	<u>SEAT BACK-REAR</u>
1356	<u>CUSHION-FRONT, OR REAR SEAT</u>
1391	<u>LOOP-SAFETY BELT</u>
1446	<u>SEAT ADJUSTMENT-FRONT</u>

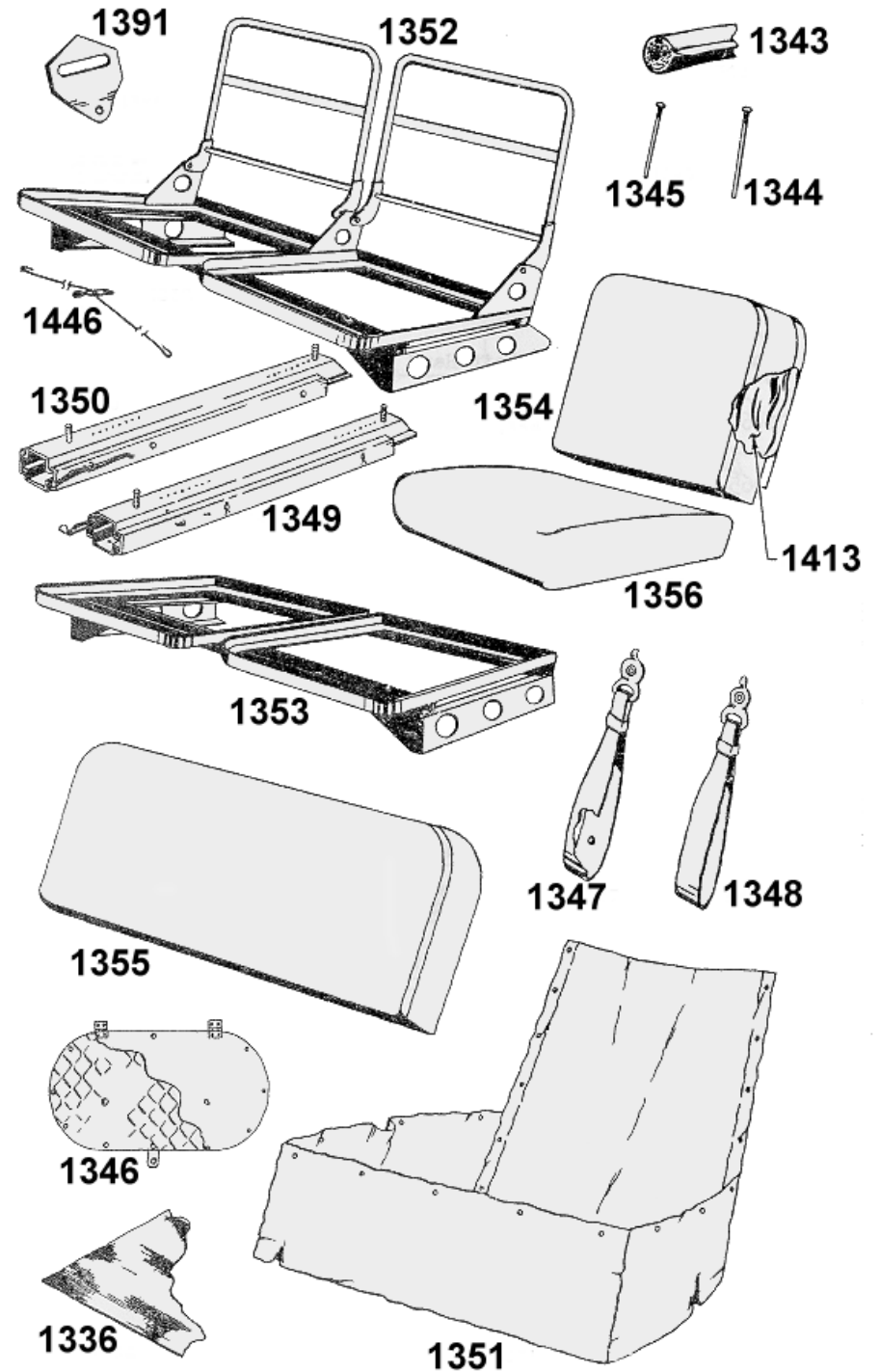

LEFT WING

<u>NUMBER</u>	<u>PART NAME</u>
1050	<u>WING ASSEMBLY-WITH ELECTRIC WIRING HYDRAULIC LINES AND CONTROLS</u>
1056	<u>Tip-Left Hand Wing with Navigation Light</u>
1057	<u>LIGHT-LEFT HAND WING TIP NAVIGATION RED</u>
1061	<u>Bellcrank-Left Hand Wing Aileron Control</u>
1062	<u>Bracket-Left Hand Wing Aileron Support</u>
1065	<u>Bracket-Left Hand Wing Flap Support</u>
1066	<u>Tube-Left Hand Wing Pitot</u>
1051	<u>FLOAT AND STRUT ASSEMBLY-LEFT HAND WING</u>
1052	<u>Float-Left Hand Wing</u>
1362	<u>PLUG-LEFT HAND WING FLOAT DRAIN</u>
1053	<u>Strut-Left Hand Wing Float</u>
1054	<u>STRUT-LEFT HAND WING LIFT WITH FAIRINGS</u>
1415	<u>Fairing-Left Hand Wing Lift Strut Upper</u>
1068	<u>Fairing-Left Hand Wing Lift Strut Lower</u>
1188	<u>FAIRING SET-LEFT HAND WING TO CABIN</u>
1058	<u>AILERON-LEFT HAND WING</u>
1064	<u>FLAP-LEFT HAND WING</u>

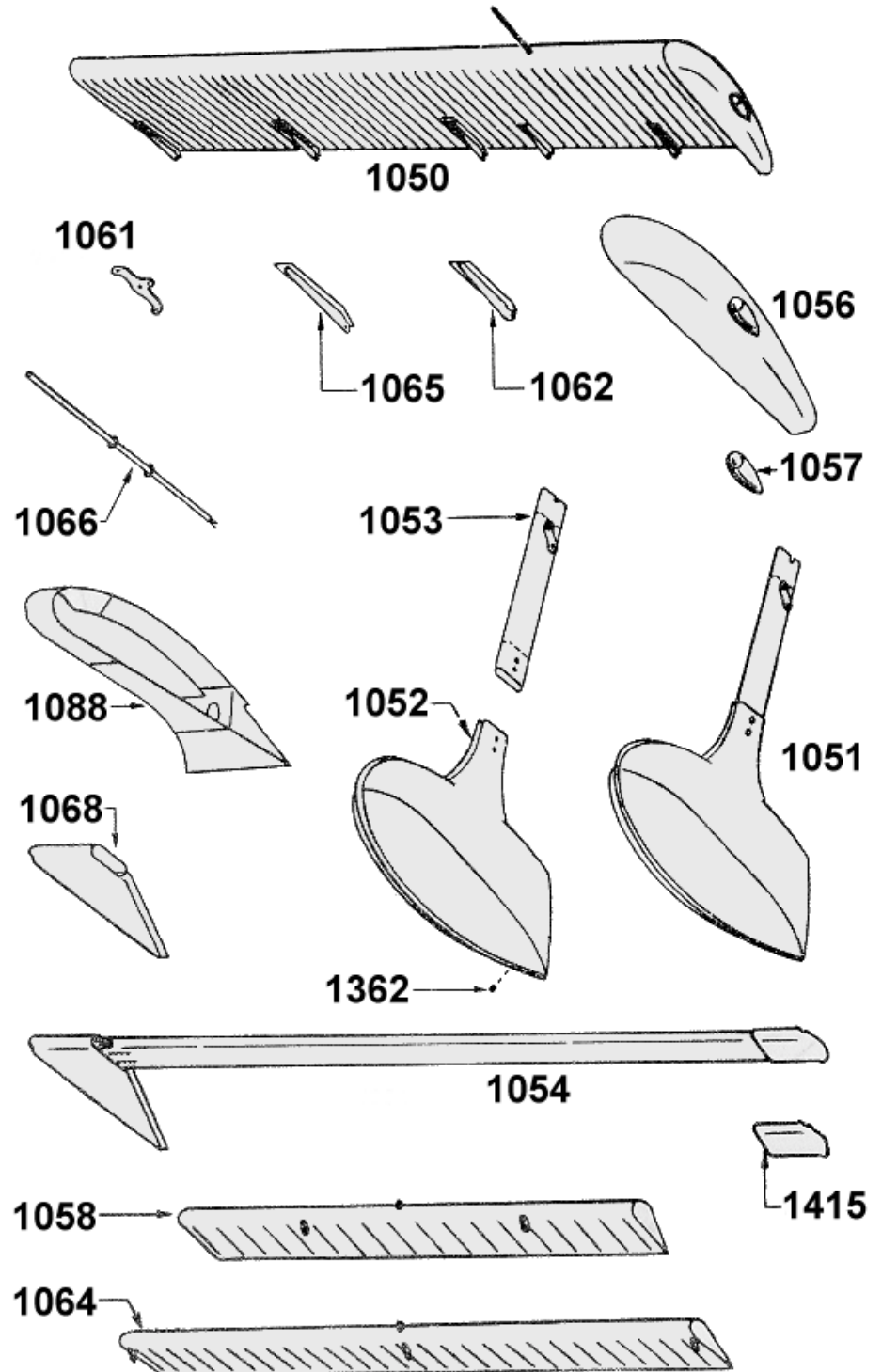

RIGHT WING

<u>NUMBER</u>	<u>PART NAME</u>
1067	<u>WING ASSEMBLY-RIGHT HAND WITH ELECTRIC WIRING, HYDRAULIC LINES AND CONTROLS</u>
1069	<u>Tip-Right Hand Wing with Navigation Light</u>
1302	<u>LIGHT-RIGHT HAND WING TIP NAVIGATION GREEN</u>
1158	<u>Bellcrank-Right Hand Wing Aileron Control</u>
1062	<u>Bracket-Right Hand Wing Aileron Support</u>
1065	<u>Bracket-Right Hand Wing Flap Support</u>
1051	<u>FLOAT AND STRUT ASSEMBLY-RIGHT HAND WING</u>
1052	<u>Float-Right Hand Wing</u>
1362	<u>PLUG-RIGHT HAND WING FLOAT DRAIN</u>
1053	<u>Strut-Right Hand Wing Float</u>
1418	<u>STRUT-RIGHT HAND WING LIFT WITH FAIRINGS</u>
1055	<u>Fairing-Right Hand Wing Lift Strut Upper</u>
1403	<u>Fairing-Right Hand Wing Lift Strut Lower</u>
1189	<u>FAIRING SET-RIGHT HAND WING TO CABIN</u>
1323	<u>AILERON-RIGHT HAND WING (WITH GROUND ADJUSTABLE TAB)</u>
1064	<u>FLAP-RIGHT HAND WING</u>

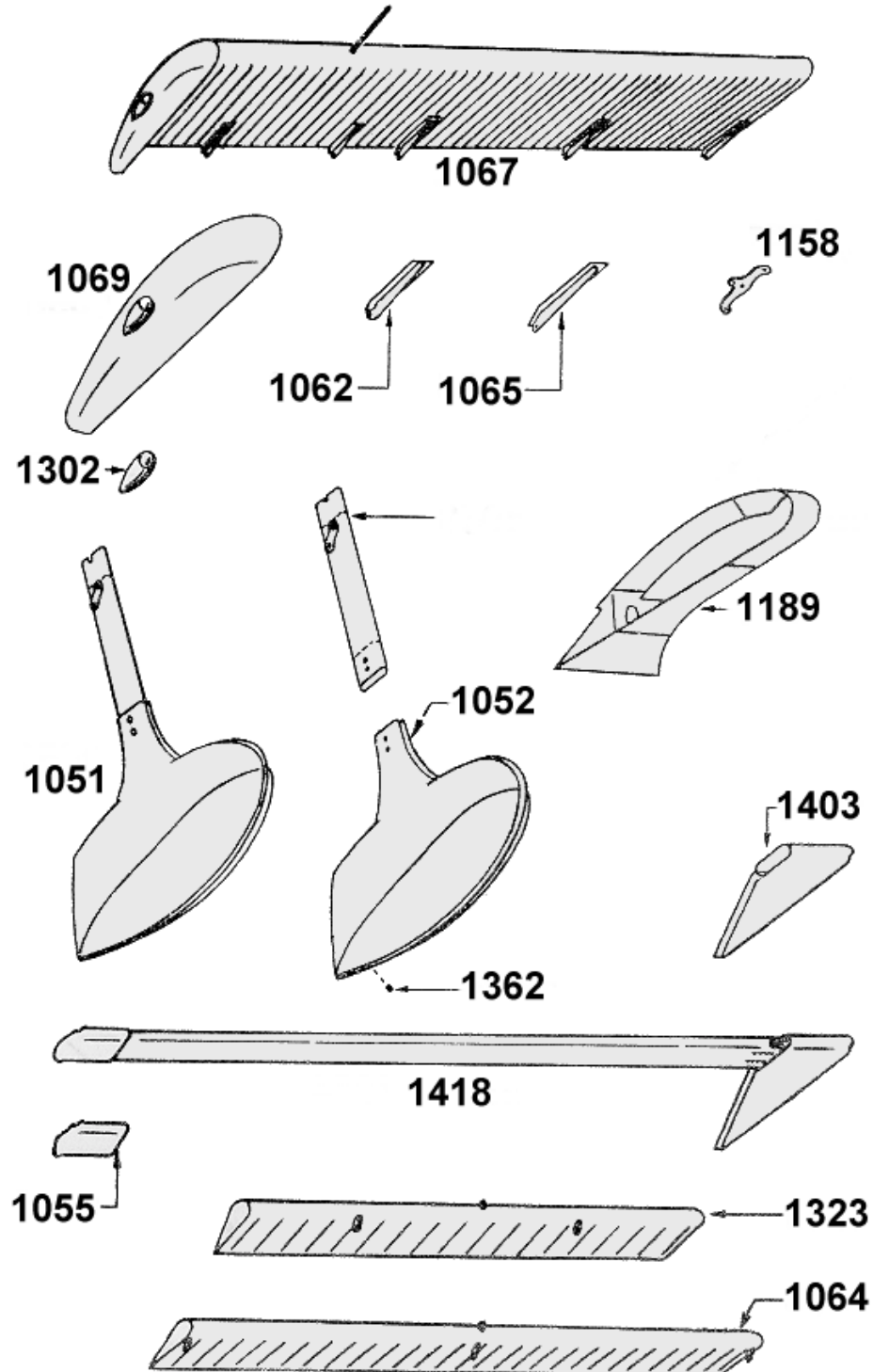

PILOT AND COPILOT CONTROL WHEELS

NUMBER	PART NAME
1203	ARM ASSEMBLY-PILO'S CONTROL WHEEL
1205	<u>Arm-Pilot's Control Wheel</u>
1209	<u>Sprocket-Pilot's Control Wheel Arm Upper</u>
1214	<u>Wheel Assembly-Pilot's Control</u>
1208	<u>Chain-Pilot's Control Wheel Arm</u>
1212	<u>Cover-Pilot's Control Wheel Arm</u>
1211	HOUSING-PILOT'S AND COPILOT'S CONTROL WHEEL ARMS
1226	<u>Snap Slide-Pilot's and Copilot's Control Wheel Arms Housing (Ships 1 to 125)</u>
1215	<u>Plug Button-Pilot's and Copilot's Control Wheel Arms Housing</u>
1225	<u>Pin-Copilot's Control Wheel Arm Release</u>
1204	ARM ASSEMBLY-COPILOT'S CONTROL WHEEL
1206	<u>Arm-Copilot's Control Wheel</u>
1209	<u>Sprocket-Copilot's Control Wheel Arm Upper</u>
1210	<u>Sprocket-Copilot's Control Wheel Arm Lower</u>
1214	<u>Wheel Assembly-Copilot's Control</u>
1208	<u>Chain-Copilot's Control Wheel Arm</u>
1212	<u>Cover-Copilot's Control Wheel Arm</u>
1216	<u>Ring-Copilot's Control Wheel Arm Retaining</u>
1217	TUBE ASSEMBLY-CONTROL WHEEL COLUMN
1218	TUBE ASSEMBLY-CONTROL WHEEL HORIZONTAL (SHIPS 5 TO 125)
1441	TUBE ASSEMBLY-CONTROL WHEEL HORIZONTAL (SHIPS 126 AND UP)
1207	<u>Sprocket-Control Wheel Horizontal Tube Assembly</u>
1219	PUSH ROD-CONTROL WHEEL COLUMN LOWER QUADRANT
1220	SIDE BRACE-CONTROL WHEEL COLUMN
1221	SUPPORT-CONTROL WHEEL COLUMN LOWER
1222	SUPPORT-CONTROL WHEEL COLUMN SIDE BRACE LOWER
1223	QUADRANT-CONTROL WHEEL COLUMN LOWER
1224	SUPPORT-CONTROL WHEEL COLUMN LOWER QUADRANT

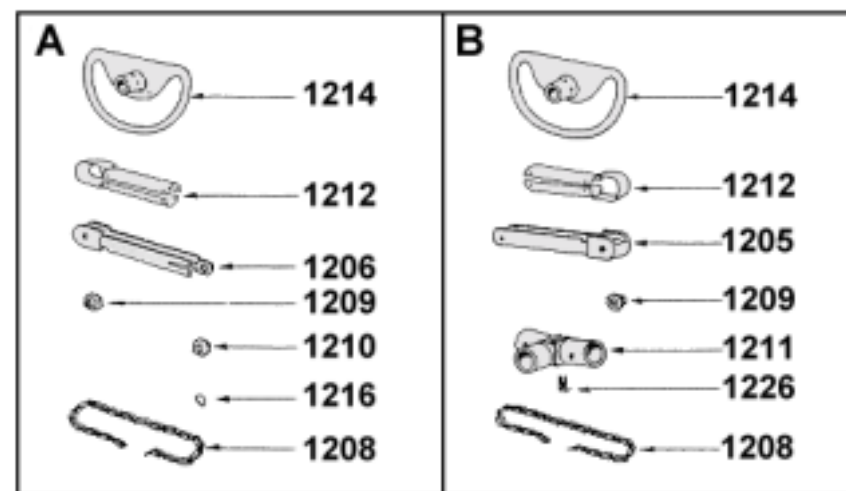
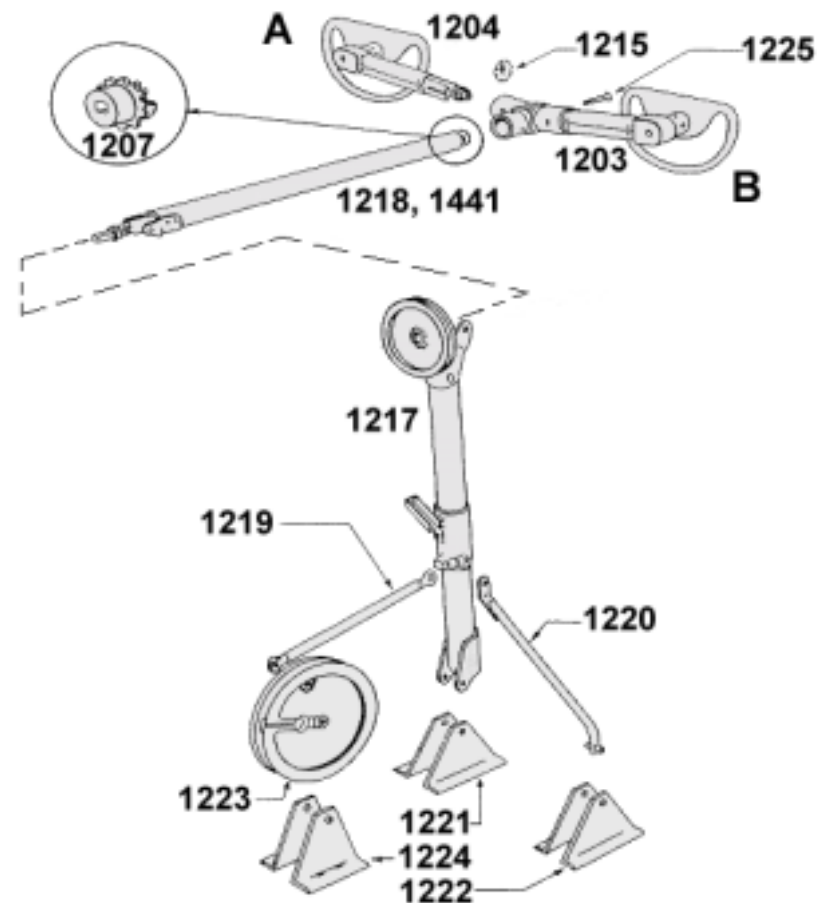

RUDDER AND BRAKE PEDALS

<u>NUMBER</u>	<u>PART NAME</u>
1192	<u>PEDAL ASSEMBLY-PILOT'S BRAKE LEFT HAND (SHIPS 1 TO 125)</u>
1432	<u>PEDAL ASSEMBLY-PILOT'S BRAKE LEFT HAND (SHIPS 126 AND UP)</u>
1194	<u>Pedal-Pilot's Brake Left Hand (Ships 1 to 125)</u>
1436	<u>Pedal-Pilot's Brake Left Hand (Ships 126 and up)</u>
1193	<u>Arm-Pilot's Brake Pedal Left Hand (Ships 1 to 125)</u>
1434	<u>Arm-Pilot's Brake Pedal Left Hand (Ships 126 and up)</u>
1192	<u>PEDAL ASSEMBLY-PILOT'S BRAKE RIGHT HAND (SHIPS 1 TO 125)</u>
1433	<u>PEDAL ASSEMBLY-PILOT'S BRAKE RIGHT HAND (SHIPS 126 AND UP)</u>
1194	<u>Pedal-Pilot's Brake Right Hand (Ships 1 to 125)</u>
1436	<u>Pedal-Pilot's Brake Right Hand (Ships 126 and up)</u>
1193	<u>Arm-Pilot's Brake Pedal Right Hand (Ships 1 to 125)</u>
1435	<u>Arm-Pilot's Brake Pedal Right Hand (Ships 126 and up)</u>
1195	<u>PEDAL ASSEMBLY-COPILOT'S RUDDER (SHIPS 1 TO 125)</u>
1437	<u>PEDAL ASSEMBLY-COPILOT'S RUDDER (SHIPS 126 AND UP)</u>
1197	<u>Pedal-Copilot's Rudder (Ships 1 to 125)</u>
1196	<u>Arm-Copilot's Rudder Pedal (Ships 1 to 125)</u>
1198	<u>ANGLE ASSEMBLY-PILOT'S BRAKE PEDAL SUPPORT LEFT HAND (SHIPS 1 TO 125)</u>
1438	<u>ANGLE ASSEMBLY-PILOT'S BRAKE PEDAL SUPPORT LEFT HAND (SHIPS 126 AND UP)</u>
1199	<u>ANGLE ASSEMBLY-PILOT'S BRAKE PEDAL SUPPORT RIGHT HAND (SHIPS 1 TO 125)</u>
1439	<u>ANGLE ASSEMBLY-PILOT'S BRAKE PEDAL SUPPORT LEFT HAND (SHIPS 126 AND UP)</u>
1227	<u>ANGLE-COPILOT'S RUDDER PEDAL SUPPORT (SHIPS 1 TO 125)</u>
1440	<u>ANGLE-COPILOT'S RUDDER PEDAL SUPPORT (SHIPS 126 AND UP)</u>
1232	<u>ANGLE-RUDDER PEDAL TORQUE TUBE SUPPORT (SHIPS 1 TO 125)</u>
1442	<u>ANGLE-RUDDER PEDAL TORQUE TUBE SUPPORT (SHIPS 126 AND UP)</u>
1200	<u>TUBE ASSEMBLY-RUDDER PEDAL TORQUE</u>
1201	<u>Gear-Rudder Pedal Torque Tube</u>

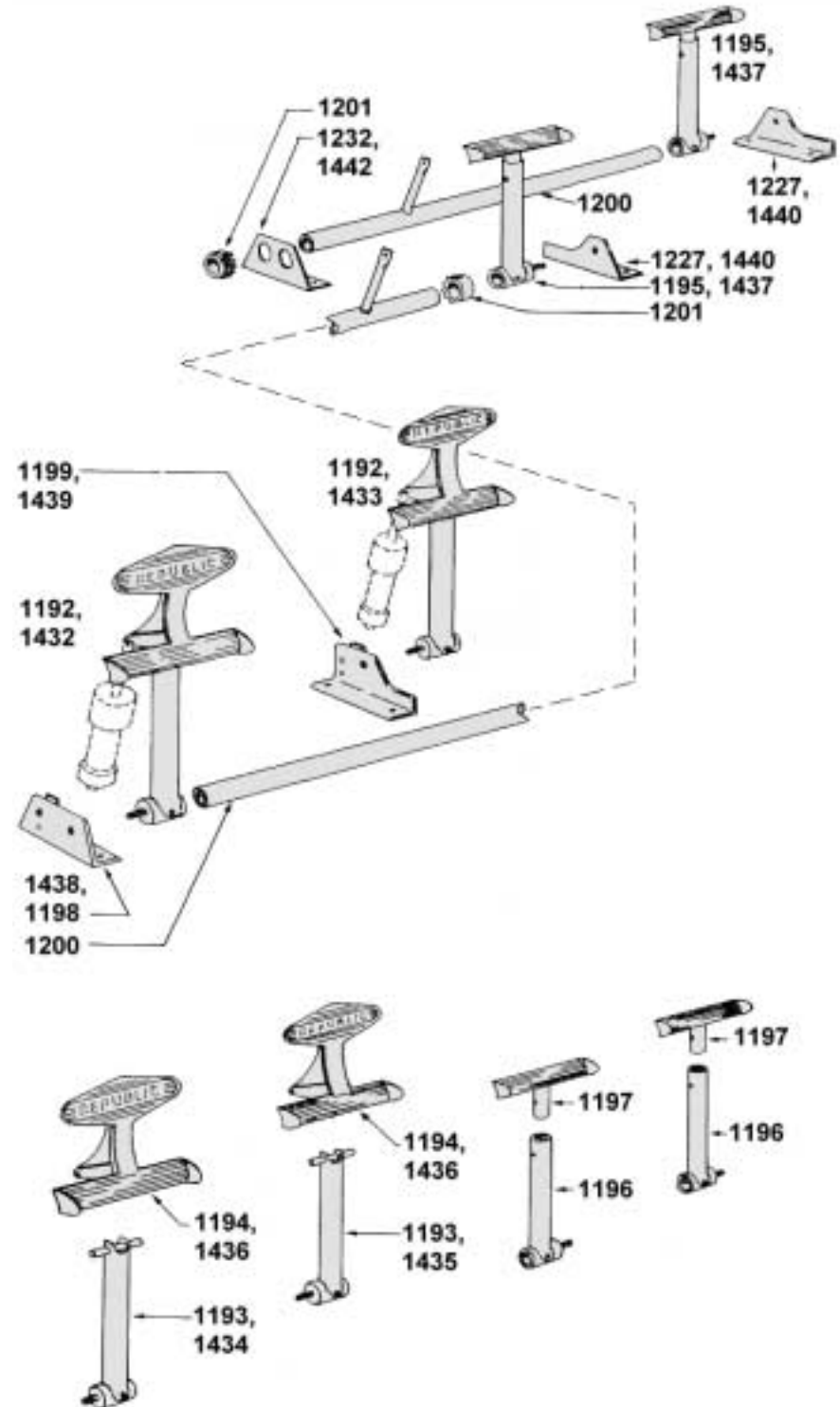

CONTROL COMPONENTS

<u>NUMBER</u>	<u>PART NAME</u>
1213	<u>CHAIN-ELEVATOR TRIM TAB CONTROL FORWARD</u>
1272	<u>CHAIN-ELEVATOR TRIM TAB CONTROL AFT</u>
1228	<u>SPRING-WATER RUDDER CABLE</u>
1234	<u>CLIP-WATER RUDDER CABLE ATTACHMENT</u>
1235	<u>CONTROL ASSEMBLY-ELEVATOR TRIM TAB</u>
1236	Crank Assembly-Elevator Trim Tab Control
1237	<u>TUBE-ELEVATOR TRIM TAB CONTROL CHAIN LEFT HAND</u>
1237	<u>TUBE-ELEVATOR TRIM TAB CONTROL CHAIN RIGHT HAND</u>
1238	<u>COVER-CABIN RUDDER CABLE (SHIPS 1 TO 125)</u>
1443	<u>COVER-CABIN RUDDER CABLE (SHIPS 126 AND UP)</u>
1239	<u>COVER-CABIN CONTROL CABLES FORWARD (SHIPS 1 TO 300)</u>
1444	<u>COVER-CABIN CONTROL CABLES FORWARD (SHIPS 301 AND UP)</u>
1240	<u>COVER-CABIN CONTROL CABLES INTERMEDIATE</u>
1241	<u>COVER-CABIN CONTROL CABLES AFT</u>
1242	<u>CABLE ASSEMBLY-HULL AILERON CONTROL LEFT HAND OR RIGHT HAND</u>
1243	<u>CABLE ASSEMBLY-HULL RUDDER CONTROL LEFT HAND</u>
1244	<u>CABLE ASSEMBLY-HULL RUDDER CONTROL RIGHT HAND</u>
1245	<u>CABLE ASSEMBLY-HULL RUDDER CONTROL AFT LEFT HAND OR RIGHT HAND</u>
1246	<u>CABLE ASSEMBLY-HULL ELEVATOR CONTROL LEFT HAND OR RIGHT HAND</u>
1247	<u>CLIP-TRIM TAB CONTROL CHAIN SPRING</u>
1248	<u>CABLE ASSEMBLY-ELEVATOR TRIM TAB LEFT HAND</u>
1401	<u>CABLE ASSEMBLY-ELEVATOR TRIM TAB RIGHT HAND</u>
1059	<u>CABLE ASSEMBLY-AILERON BALANCE WING LEFT HAND</u>
1191	<u>CABLE ASSEMBLY-AILERON BALANCE WING RIGHT WING</u>
1060	<u>CABLE ASSEMBLY-AILERON CONTROL WING LEFT HAND</u>
1419	<u>CABLE ASSEMBLY-AILERON CONTROL WING RIGHT HAND</u>
1063	<u>ROD ASSEMBLY-AILERON BELLCRANK CONTROL LEFT HAND</u>
1063	<u>ROD ASSEMBLY-AILERON BELLCRANK CONTROL RIGHT HAND</u>

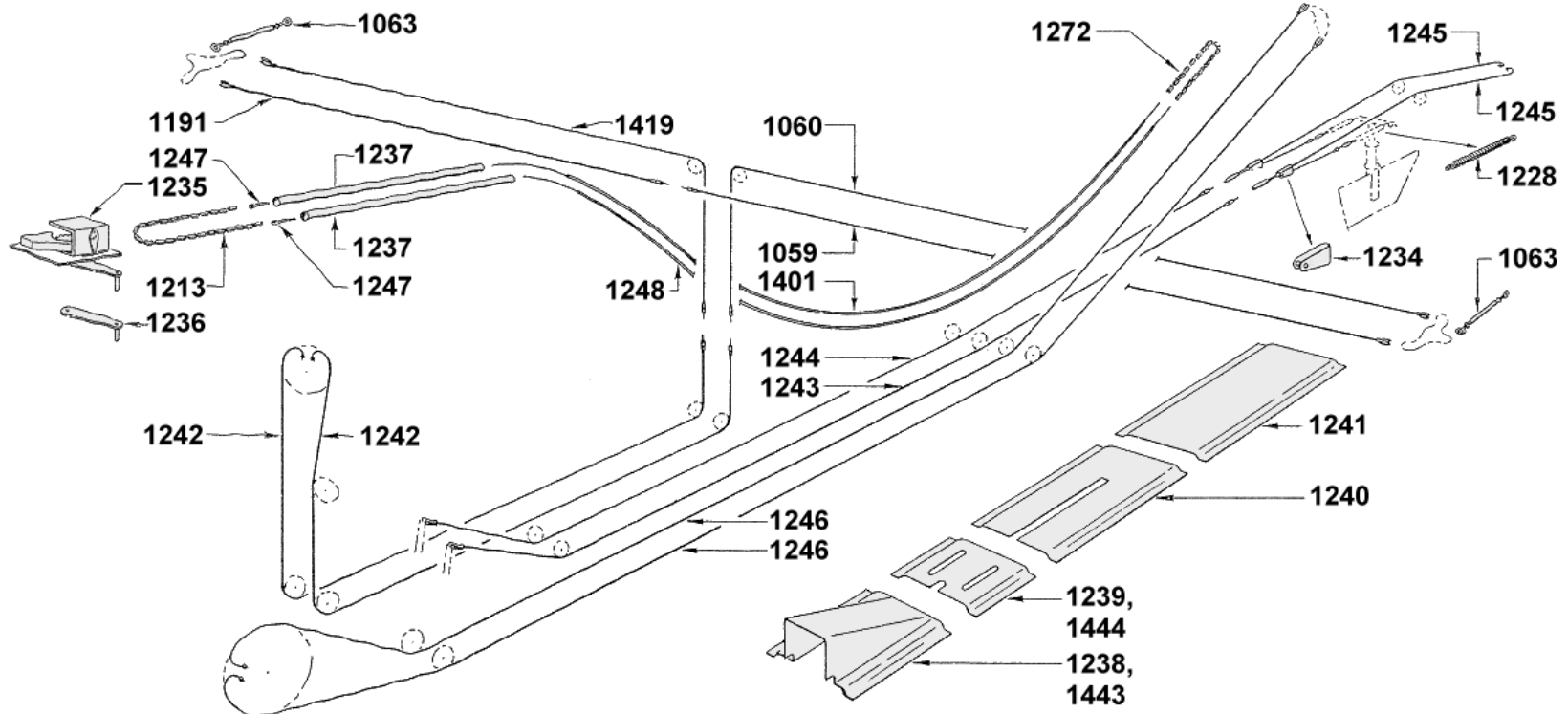

CONTROL COMPONENTS (CONT.)

<u>NUMBER</u>	<u>PART NAME</u>
1324	<u>SPROCKET INSTALLATION-ELEVATOR TRIM TAB</u>
1325	<u>GEAR ASSEMBLY-ELEVATOR TRIM TAB LEFT HAND</u>
1327	<u>Rod Assembly-Elevator Trim Tab Left Hand</u>
1326	<u>GEAR ASSEMBLY-ELEVATOR TRIM TAB RIGHT HAND</u>
1327	<u>Rod Assembly-Elevator Trim Tab Right Hand</u>
1328	<u>FORK-ELEVATOR TRIM TAB LEFT HAND</u>
1328	<u>FORK-ELEVATOR TRIM TAB RIGHT HAND</u>
1329	<u>SHAFT ASSEMBLY-ELEVATOR TRIM TAB FLEXIBLE</u>

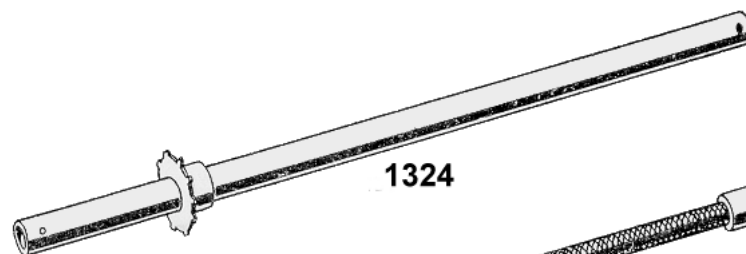

1324

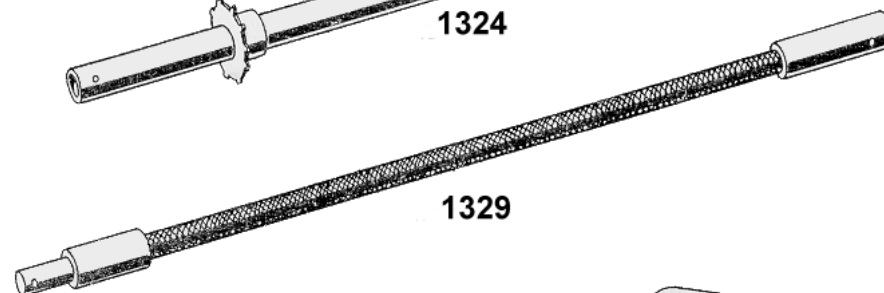

1329

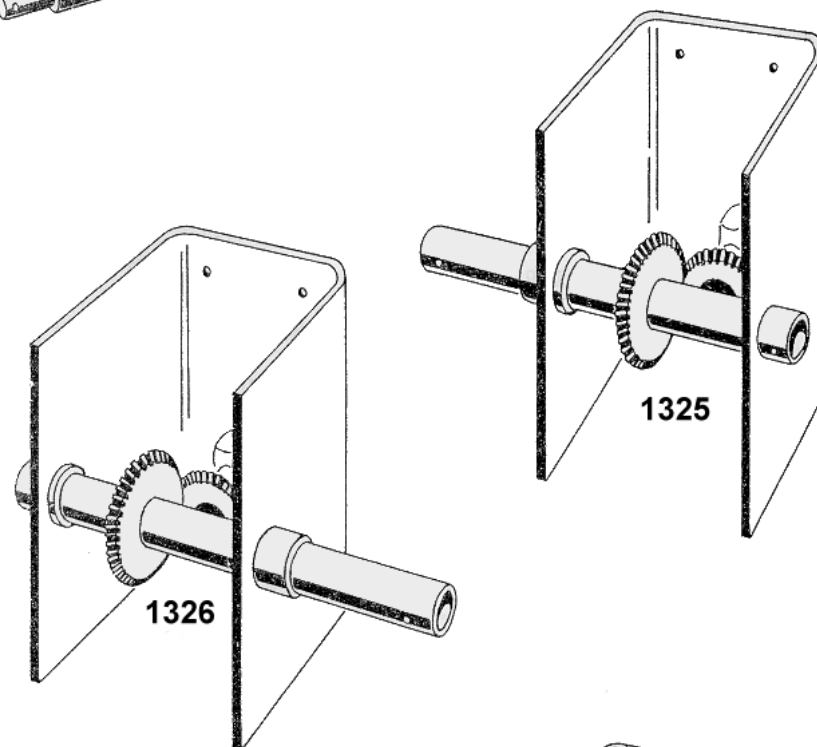

1325

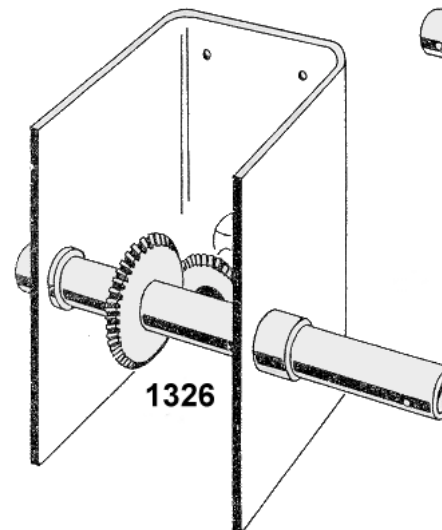

1326



1328



1327

HYDRAULIC SYSTEM

<u>NUMBER</u>	<u>PART NAME</u>
1144	<u>CYLINDER-TAIL WHEEL HYDRAULIC ACTUATING</u>
1182	<u>VALVE-BRAKE ADJUSTER</u>
1148	<u>POWER PAK-HYDRAULIC SYSTEM</u>
1149	<u>CYLINDER-LANDING GEAR RETRACTING HYDRAULIC</u>
1150	<u>CYLINDER-WING FLAP HYDRAULIC</u>
1152	<u>VALVE ASSEMBLY-PARKING BRAKE (SHIPS 1 to 125 ONLY)</u>
1429	<u>VALVE ASEMBLY-PARKING BRAKE (SHIPS 126 AND UP)</u>
1153	<u>CONTROL-PARKING BRAKE PUSH-PULL (SHIPS 6 to 125)</u>
1146	<u>CONTROL-PARKING BRAKE PUSH-PULL(SHIPS 125 AND UP)</u>
1154	<u>CONNECTOR-BRAKE HYDRAULIC BLEEDER</u>
1155	<u>Gasket-Brake Hydraulic Bleeder Connector</u>
1156	<u>Nut-Brake Hydraulic Bleeder Connector</u>
1157	<u>CYLINDER-MASTER BRAKE</u>
1427	<u>KIT-HYDRAULIC CYLINDER PACKING (NOT ILLUSTRATED)</u>
1070	<u>KIT-BRAKE ADJUSTER PACKING (NOT ILLUSTRATED)</u>
1114	<u>KIT-ON-OFF VALVE PACKING (NOT ILLUSTRATED)</u>
1115	<u>KIT-LANDING GEAR RETRACTING CYLINDER PACKING(NOT ILLUSTRATED)</u>
1151	<u>KIT-BRAKE CYLINDER PACKING (NOT ILLUSTRATED)</u>
1229	<u>KIT-WING FLAP CYLINDER PACKING (NOT ILLUSTRATED)</u>
1399	<u>KIT-POWER PAK PACKING (NOT ILLUSTRATED)</u>
1400	<u>KIT-TAIL WHEEL CYLINDER PACKING (NOT ILLUSTRATED)</u>

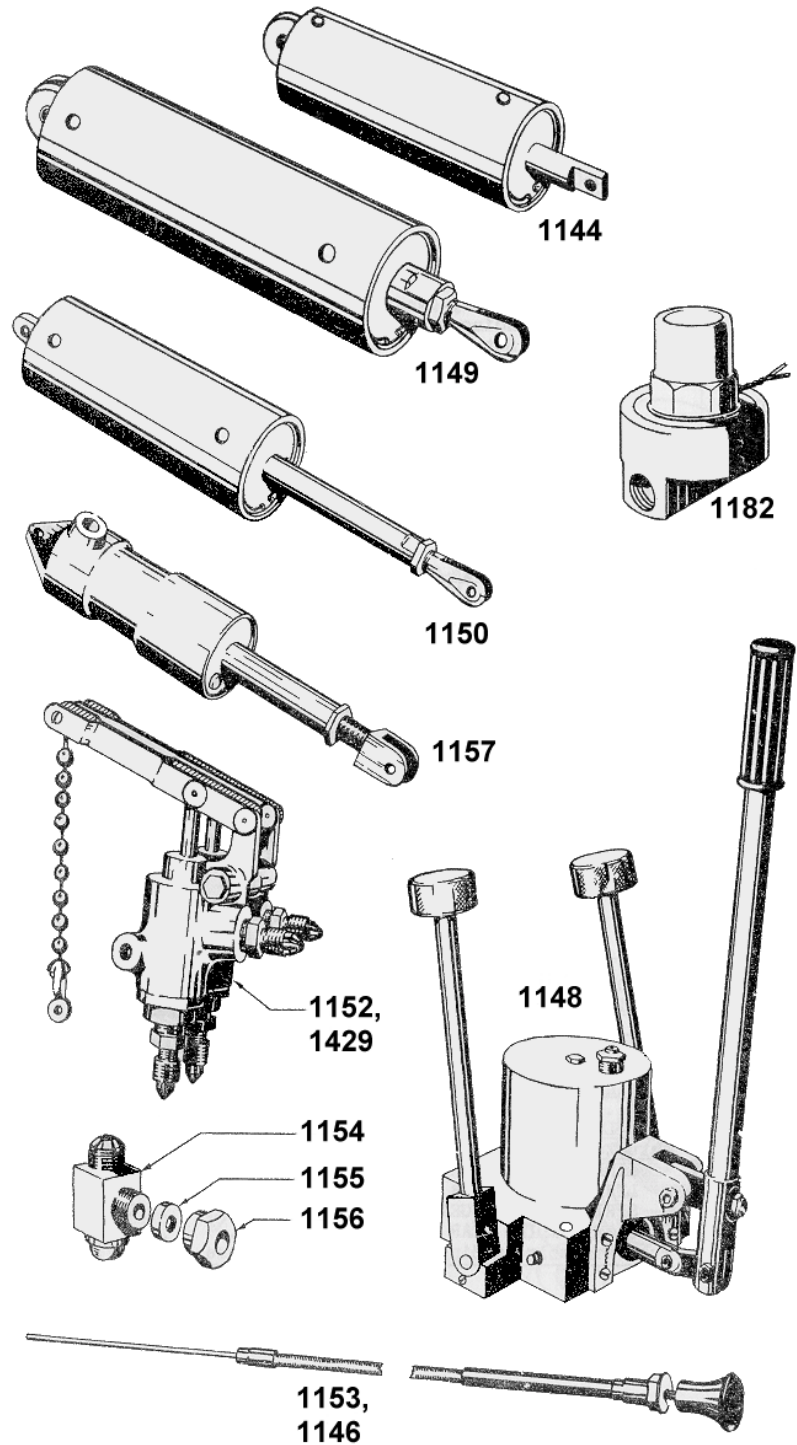

LANDING GEAR

<u>NUMBER</u>	<u>PART NAME</u>
1089	<u>GEAR INSTALLATION-LEFT HAND LANDING</u>
1090	<u>Strut Assembly-Left Hand Landing Gear</u>
1091	FLANGE-LANDING GEAR BRAKE LEFT HAND OR RIGHT HAND .
1092	AXLE-LANDING GEAR STRUT LEFT HAND OR RIGHT HAND
1093	SCISSORS-LANDING GEAR STRUT LEFT HAND OR RIGHT HAND
1094	GASKET KIT-LANDING GEAR STRUT LEFT HAND OR RIGHT HAND
1095	VALVE-LANDING GEAR HIGH PRESSURE AIR LEFT HAND OR RIGHT HAND
1096	WHEEL AND BRAKE ASSEMBLY-LANDING GEAR LEFT HAND OR RIGHT HAND
1097	Brake Assembly-Landing Gear Left Hand or Right Hand.....
1098	Wheel-Landing Gear Left Hand or Right Hand
1099	Bearing Set-Landing Gear Wheel Left hand or Right Hand
1100	Tire-Landing Gear Aircraft Left Hand or Right Hand
1101	Tube-Landing Gear Aircraft Tire Inner Left Hand or Right Hand
1103	NUT-LANDING GEAR AXLE LEFT HAND OR RIGHT HAND
1104	COLLAR-LANDING GEAR WHEEL LEFT HAND OR RIGHT HAND
1108	<u>Bearing-Landing Gear Cross Tube Outboard Left Hand or Right Hand</u>
1025	SEAL-LANDING GEAR CROSS TUBE OUTBOARD BEARING LEFT HAND OR RIGHT HAND
1109	<u>Bearing-Landing Gear Cross Tube Inboard Left Hand or Right Hand</u>
1102	<u>Tube-Landing Gear Cross Left Hand or Right Hand</u>
1105	<u>GEAR INSTALLATION-RIGHT HAND LANDING</u>
1106	<u>Strut Assembly-Right Hand Landing Gear</u>
1091	FLANGE-LANDING GEAR BRAKE RIGHT HAND OR LEFT HAND .
1092	AXLE-LANDING GEAR STRUT RIGHT HAND OR LEFT HAND
1093	SCISSORS-LANDING GEAR STRUT RIGHT HAND OR LEFT HAND
1094	GASKET KIT-LANDING GEAR STRUT RIGHT HAND OR LEFT HAND
1095	VALVE-LANDING GEAR HIGH PRESSURE AIR RIGHT HAND OR LEFT HAND
1096	WHEEL AND BRAKE ASSEMBLY-LANDING GEAR RIGHT HAND OR LEFT HAND
1097	Brake Assembly-Landing Gear Right Hand or Left Hand.....
1098	Wheel-Landing Gear Right Hand or Left Hand
1099	Bearing Set-Landing Gear Right Hand or Left Hand.....
1100	Tire-Landing Gear Aircraft Right Hand or Left Hand
1101	Tube-Landing Gear Aircraft Tire Inner Right Hand or Left Hand
1103	NUT-LANDING GEAR AXLE RIGHT HAND OR LEFT HAND
1104	COLLAR-LANDING GEAR WHEEL RIGHT HAND OR LEFT HAND
1108	<u>Bearing-Landing Gear Cross Tube Outboard Right Hand or Left Hand</u>
1025	SEAL-LANDING GEAR OUTBOARD BEARING RIGHT HAND OR LEFT HAND
1109	<u>Bearing-Landing Gear Cross Tube Inboard Right Hand or Left Hand</u>
1102	<u>Tube-Landing Gear Cross Right Hand or Left Hand</u>
1107	<u>Actuator Installation-Landing Gear</u>
1111	LINK-LANDING GEAR ACTUATOR UPPER LOCK.....
1112	LINK-LANDING GEAR ACTUATOR LOWER LOCK.....
1113	SPRING-LANDING GEAR ACTUATOR DOWNLOCK
1402	CLIP-LANDING GEAR LOCK SPRING.....
1110	Tube Assembly-Landing Gear Actuator Torque

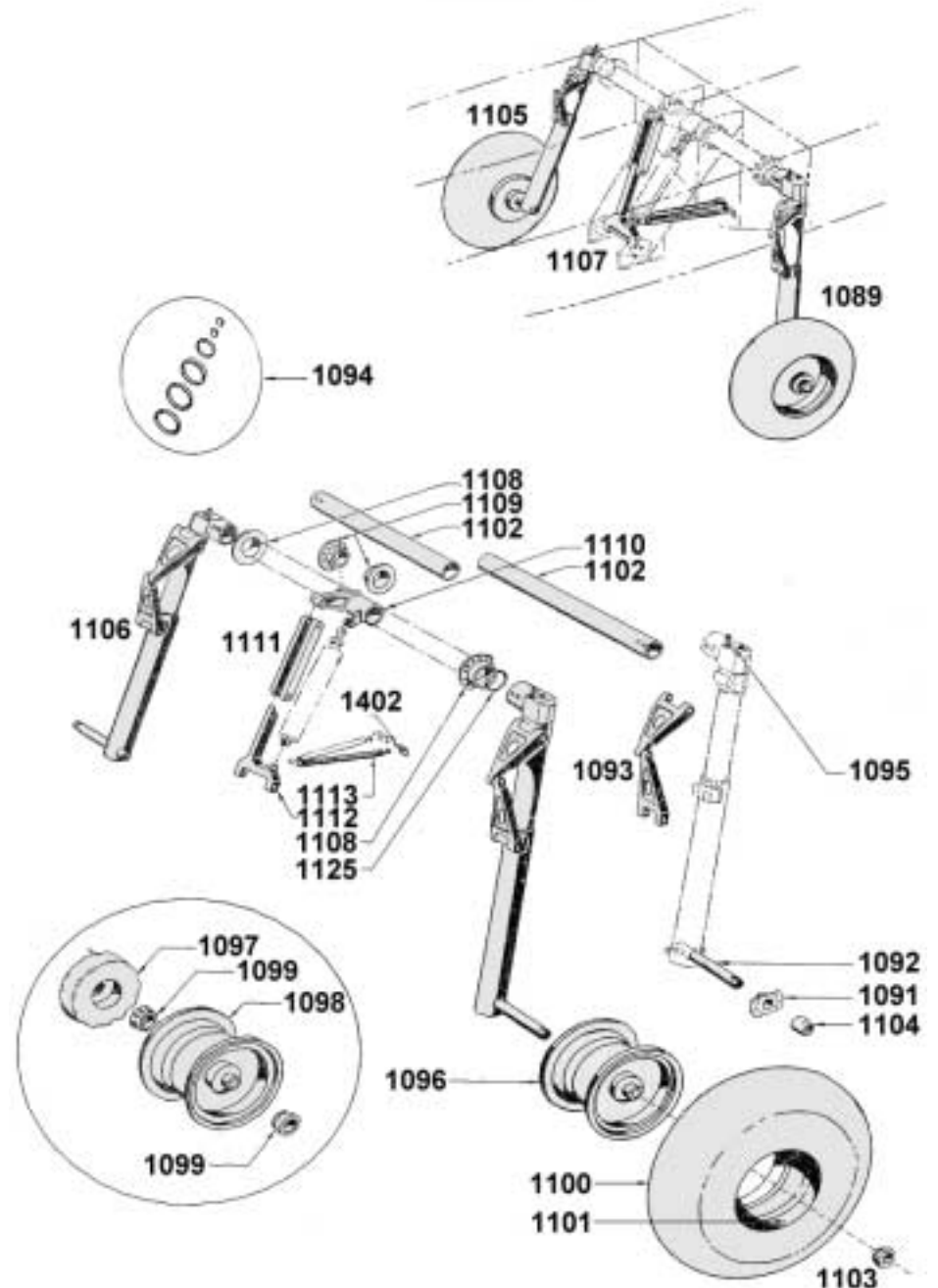

TAIL WHEEL

<u>NUMBER</u>	<u>PART NAME</u>
1116	<u>YOKE AND FORK ASSEMBLY-TAIL WHEEL</u>
1122	<u>Yoke Assembly-Tail Wheel</u>
1426	<u>Wheel Assembly-Tail</u>
1123	<u>Fork Assembly-Tail Wheel</u>
1141	FORK-TAIL WHEEL
1142	SPINDLE-TAIL WHEEL LOCK PIN
1230	PLATE-TAIL WHEEL LOCK PIN
1143	FILLER-TAIL WHEEL FORK ASSEMBLY
1117	<u>Spacer-Tail Wheel Axle</u>
1118	<u>Tire-Tail Wheel Aircraft</u>
1119	<u>Tube-Tail Wheel Aircraft Tire Inner</u>
1120	<u>Axle-Tail Wheel</u>
1121	<u>Shim-Tail Wheel Shaft</u>
1124	<u>SPACER-TAIL WHEEL SHOCK ABSORBER</u>
1125	<u>SHAFT ASSEMBLY-TAIL WHEEL SHOCK ABSORBER</u>
1126	<u>COLLAR-TAIL WHEEL SHOCK ABSORBER</u>
1127	<u>TUBE-TAIL WHEEL SHOCK ABSORBER</u>
1128	<u>PISTON-TAIL WHEEL SHOCK ABSORBER</u>
1129	<u>DISC-TAIL WHEEL SHOCK ABSORBER</u>
1130	<u>BEARING ASSEMBLY-TAIL WHEEL DOWNLOCK</u>
1414	<u>Seal Tail Wheel Downlock Bearing, Oil</u>
1131	<u>PLATE-TAIL WHEEL SHOCK ABSORBER</u>
1132	<u>SPRING-TAIL WHEEL ACTUATING LOCK</u>
1133	<u>BRACKET ASSEMBLY-TAIL WHEEL LOCK PULLEY</u>
1134	<u>SLEEVE-TAIL WHEEL SHOCK ABSORBER</u>
1135	<u>PLATE ASSEMBLY-TAIL WHEEL YOKE FRICTION</u>
1136	<u>TUBE ASSEMBLY-TAIL WHEEL ACTUATING TORQUE</u>
1137	<u>LINK ASSEMBLY-TAIL WHEEL ACTUATING LOWER</u>
1138	<u>TUBE ASSEMBLY-TAIL WHEEL ACTUATING</u>
1139	<u>SUPPORT-TAIL WHEEL ACTUATING TUBE</u>
1140	<u>SHIM-TAIL WHEEL ACTUATING SUPPORT</u>
1145	<u>COLLAR-TAIL WHEEL SHOCK ABSORBER TUBE FORWARD</u>
1231	<u>WASHER-TAIL WHEEL FORK RETAINING SPRING</u>

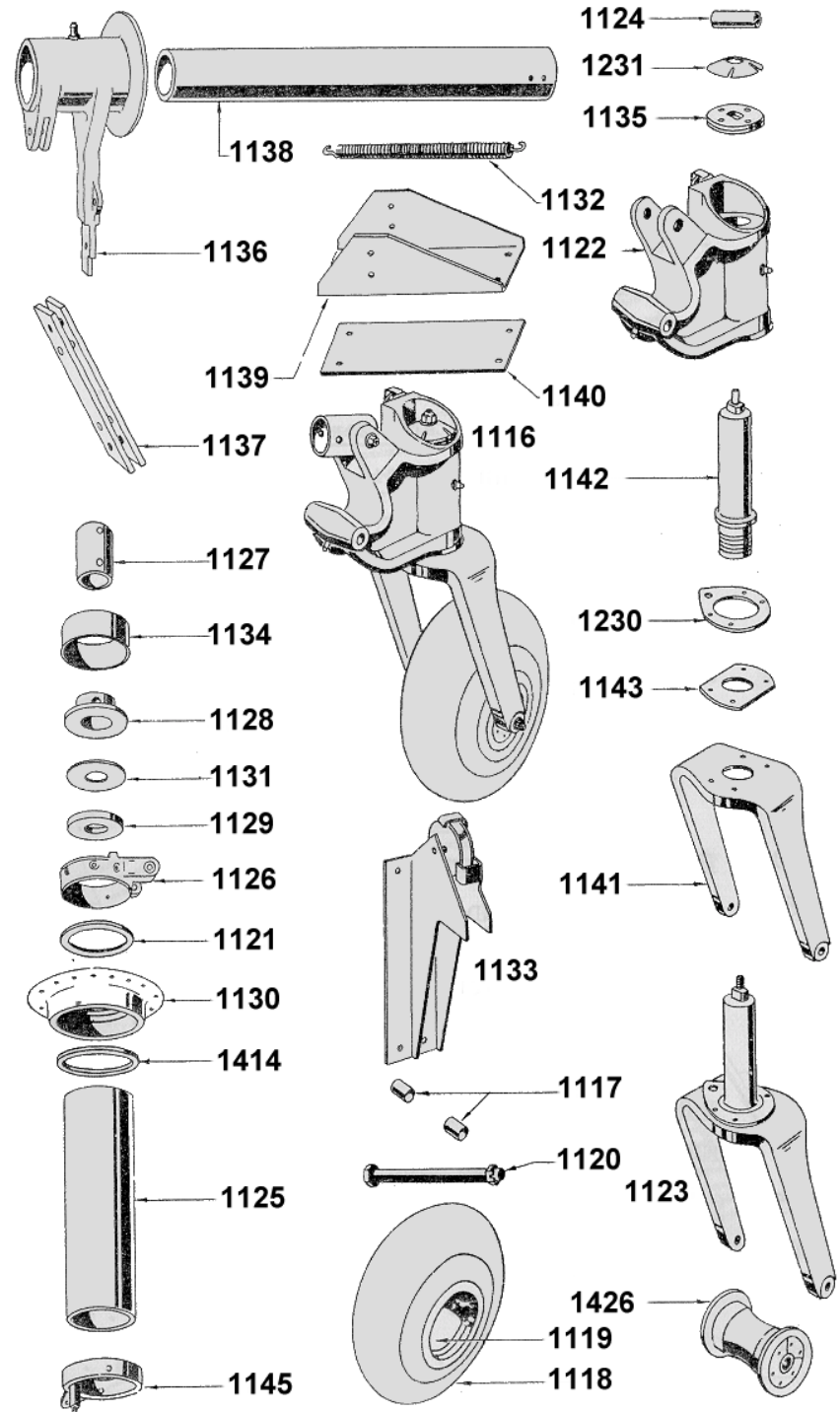

EMPENNAGE

<u>NUMBER</u>	<u>PART NAME</u>
1071	<u>FIN-WITH ELECTRIC WIRING AND ANCHOR LIGHT</u>
1072	<u>Light-Fin Anchor</u>
1073	<u>RUDDER-WITH ELECTRICAL WIRING AND NAVIGATION LIGHT</u>
1379	<u>Plug Button-Rudder or Elevator</u>
1420	<u>Light-Rudder Navigation</u>
1074	<u>STABILIZER-LEFT HAND (WITH TRIM TAB CONTROLS)</u>
1075	<u>Hinge-Left Hand Stabilizer Outboard</u>
1076	<u>Hinge-Left Hand Stabilizer Inboard</u>
1077	<u>STABILIZER-RIGHT HAND (WITH TRIM CONTROLS)</u>
1075	<u>Hinge-Right Hand Stabilizer Outboard</u>
1076	<u>Hinge-Right Hand Stabilizer Inboard</u>
1078	<u>ELEVATOR-LEFT HADN (LESS TRIM TAB)</u>
1379	<u>Plug Button-Elevator or Rudder</u>
1080	<u>Hinge-Left Hand Elevator Outboard</u>
1079	<u>Hinge-Left Hand Elevator Inboard</u>
1081	<u>TRIM TAB-LEFT HAND ELEVATOR</u>
1082	<u>ELEVATOR-RIGHT HAND (LESS TRIM TAB)</u>
1379	<u>Plug Button-Elevator or Rudder</u>
1080	<u>Hinge-Left Hand Elevator Outboard</u>
1079	<u>Hinge-Left Hand Elevator Inboard</u>
1083	<u>TRIM TAB-RIGHT HAND ELEVATOR</u>
1084	<u>TUBE ASSEMBLY-ELEVATOR TORQUE</u>
1085	<u>QUADRANT ASSEMBLY-RUDDER</u>
1086	<u>RUDDER ASSEMBLY-WATER (WITH POST)</u>
1087	<u>Rudder-Water</u>
1088	<u>Post-Water Rudder</u>

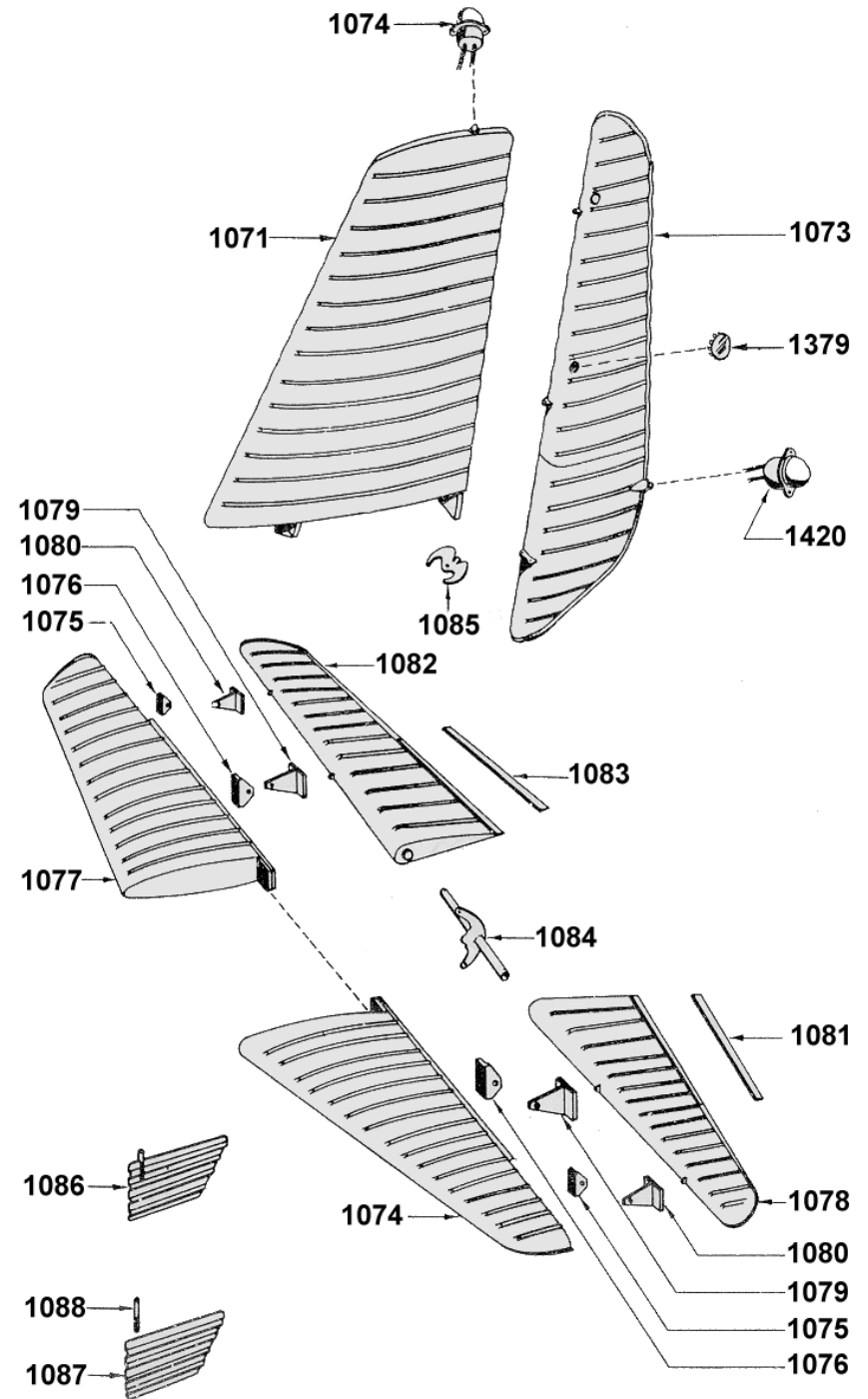

ENGINE AND PROPELLER

<u>NUMBER</u>	<u>PART NAME</u>
1275	<u>ENGINE-FRANKLIN MODEL 6AL-500</u>
1273	<u>PROPELLER-KOPPERS (FIXED PITCH GROUND ADJUSTABLE)</u>
1274	<u>PROPELLER-HARTZELL (CONTROLLABLE PITCH, REVERSIBLE)</u>
1395	<u>Hose Assembly-Propeller Pitch Change Hydraulic Return</u>
1396	<u>Hose Assembly-Propeller Pitch Change Hydraulic Inlet</u>
1397	<u>Valve-Propeller Pitch Check</u>
1398	<u>Gasket-Propeller Cylinder</u>

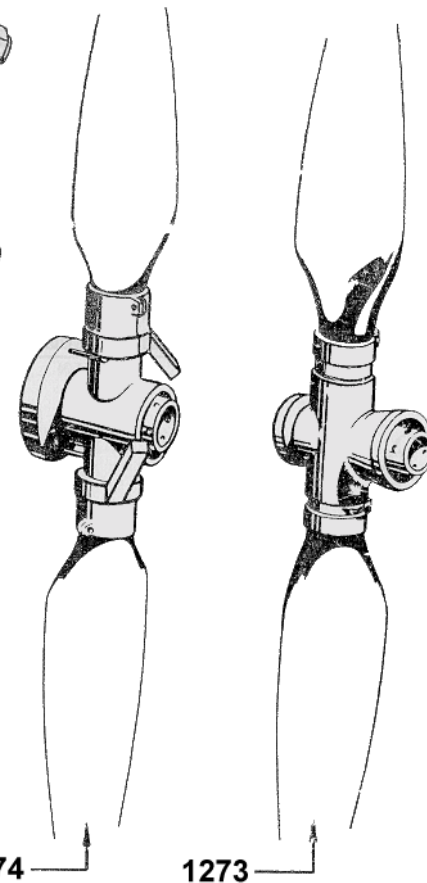
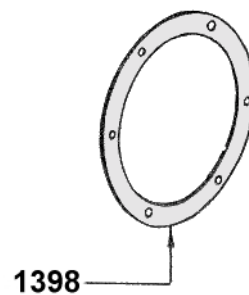
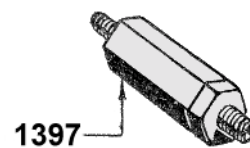
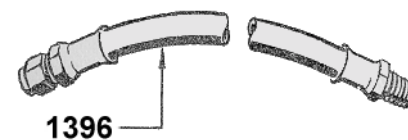
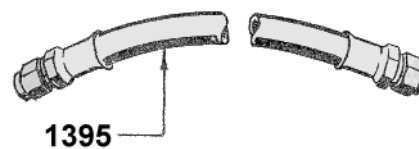
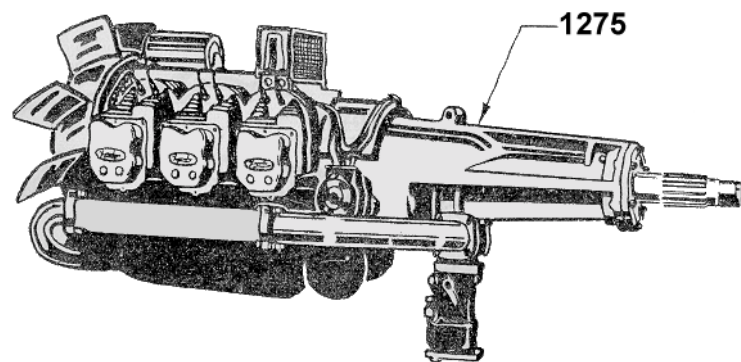

ENGINE MOUNT

<u>NUMBER</u>	<u>PART NAME</u>
1033	<u>MOUNT INSTALLATION-ENGINE</u>
1303	<u>Tube Assembly-Left Hand Engine Mount</u>
1304	<u>Tube Assembly-Right Hand Engine Mount</u>
1305	<u>Channel Assembly-Right Hand Engine Mount Forward</u>
1305	<u>Channel Assembly-Left Hand Engine Mount Forward</u>
1306	<u>Channel Assembly-Right Hand Engine Mount Rear</u>
1306	<u>Channel Assembly-Left Hand Engine Mount Rear</u>
1307	<u>Shock Mount Assembly-Engine Rear Left Hand</u>
1307	<u>Shock Mount Assembly-Engine Rear Right Hand</u>
1308	<u>Shock Mount Assembly-Engine Front</u>

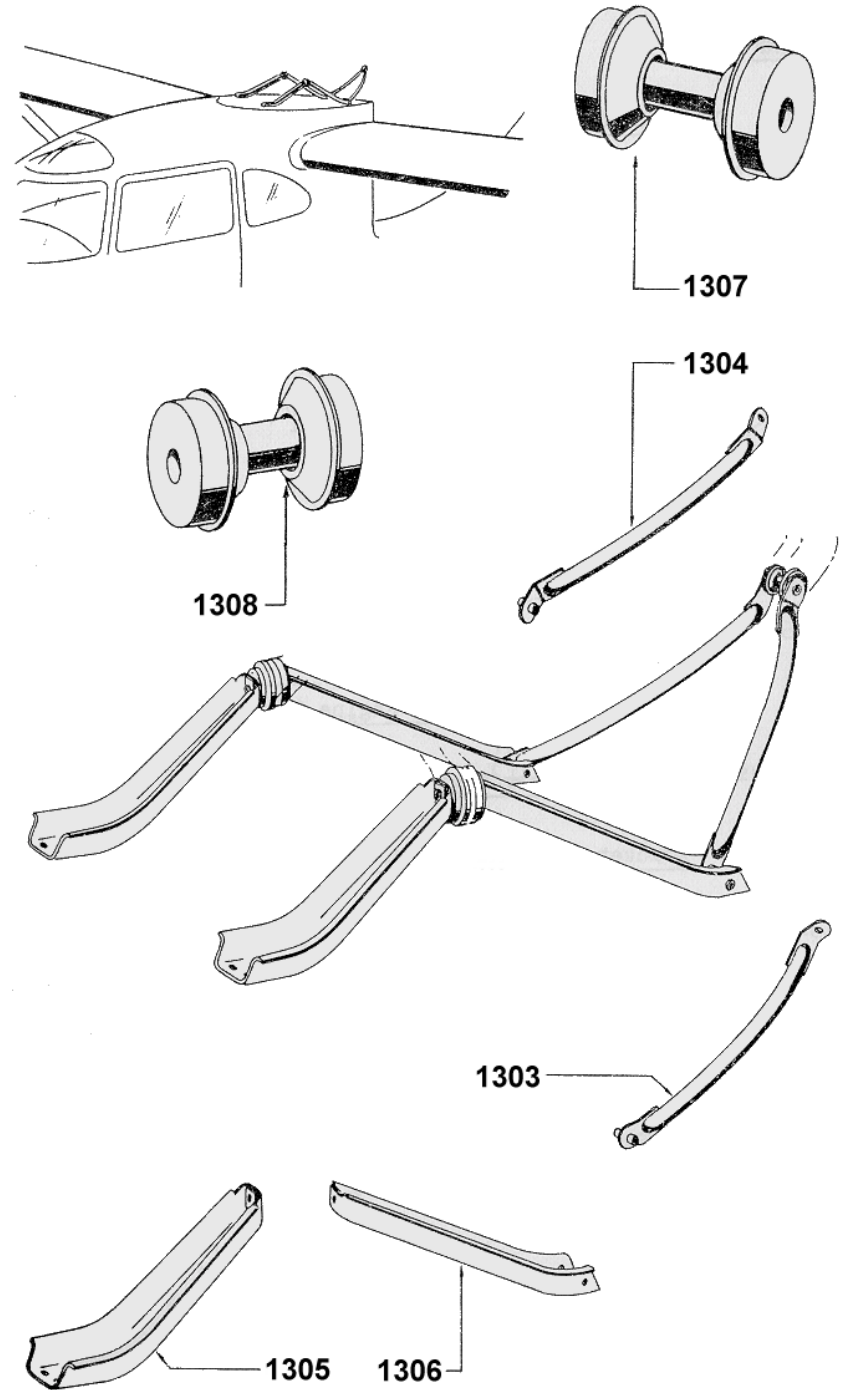

ENGINE COWL

<u>NUMBER</u>	<u>PART NAME</u>
1309	<u>COWL ASSEMBLY-RIGHT HAND LOWER ENGINE</u>
1310	<u>COWL ASSEMBLY-LEFT HAND LOWER ENGINE</u>
1311	<u>COWL ASSEMBLY-TOP ENGINE</u>
1312	<u>COWL ASSEMBLY-FRONT ENGINE</u>
1313	<u>Link-Front Engine Cowl Forward</u>
1314	<u>Link-Front Engine Cowl Rear</u>
1315	<u>Bracket assembly-Left Hand Front Engine Cowl</u>
1316	<u>Bracket Assembly-Right Hand Front Engine Cowl</u>
1317	<u>Grille Assembly-Front Engine Cowl</u>
1318	<u>Latch Assembly-Engine Cowl</u>
1319	<u>Bracket Assembly-Left Hand Front Cowl Support</u>
1320	<u>Bracket Assembly-Right Hand Front Cowl Support</u>
1321	<u>Bracket Assembly-Left Hand Rear Cowl Support</u>
1322	<u>Bracket Assembly-Right Hand Rear Cowl Support</u>
1392	<u>Molding-Engine Cowl Rubber</u>

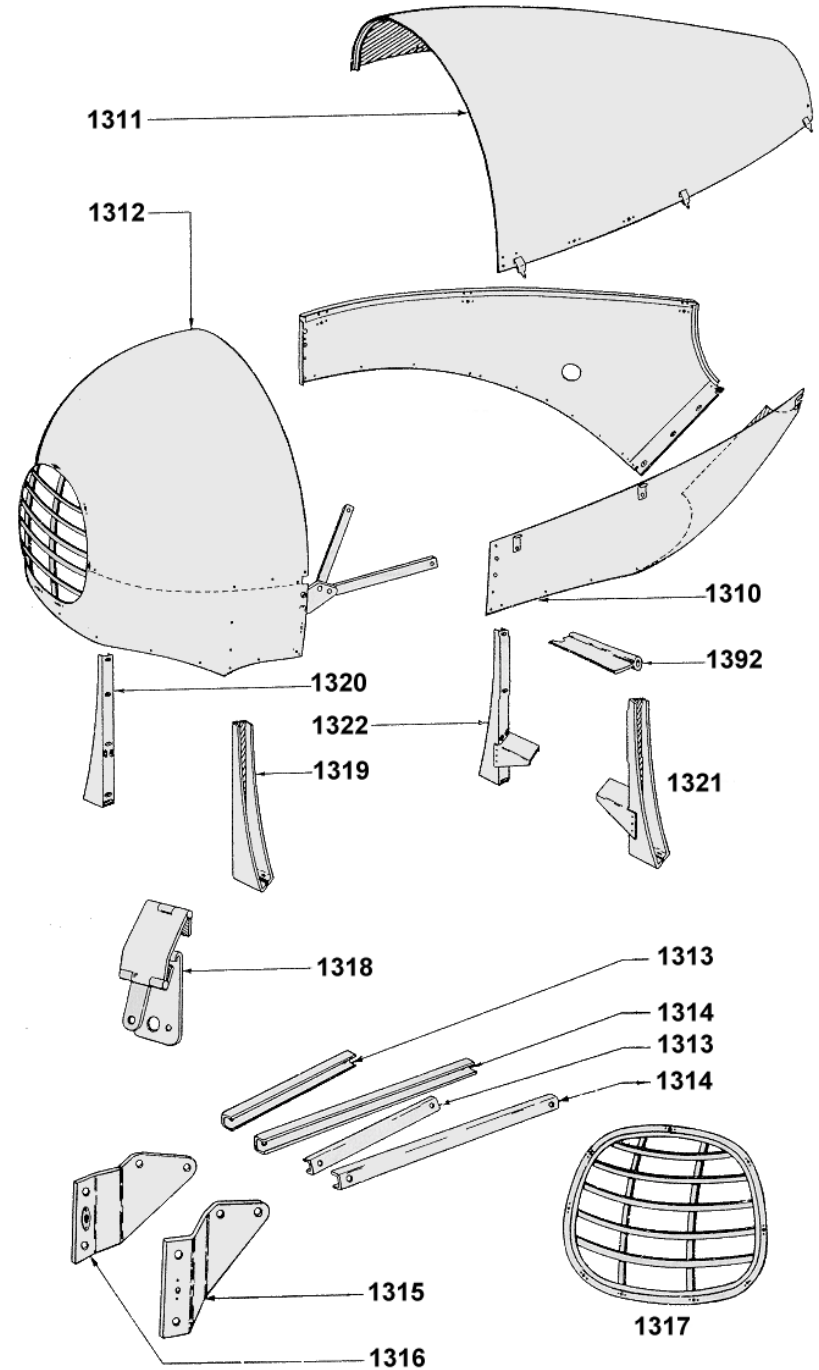

ENGINE AND PROPELLER CONTROLS

<u>NUMBER</u>	<u>PART NAME</u>
1380	<u>CONTROL UNIT-REVERSIBLE PITCH PROPELLER</u>
1381	<u>Lever-Propeller Reverse Control Unit</u>
1382	<u>Spring-Propeller Reverse Control Lock</u>
1383	<u>Knob-Propeller reverse Control</u>
1384	<u>Plate-Propeller Reverse Control Instruction</u>
1385	<u>Bracket-Reversible Propeller Control</u>
1394	<u>Lock Assembly-Propeller reverse Control Unit Safety</u>
1389	<u>CONTROL-MIXTURE</u>
1386	<u>Bolt-Mixture Control Attachment</u>
1387	<u>CONTROL-THROTTLE PUSH-PULL</u>
1388	<u>CONTROL-PROPELLER PITCH</u>
1390	<u>CONTROL-CARBURETOR HEAT</u>

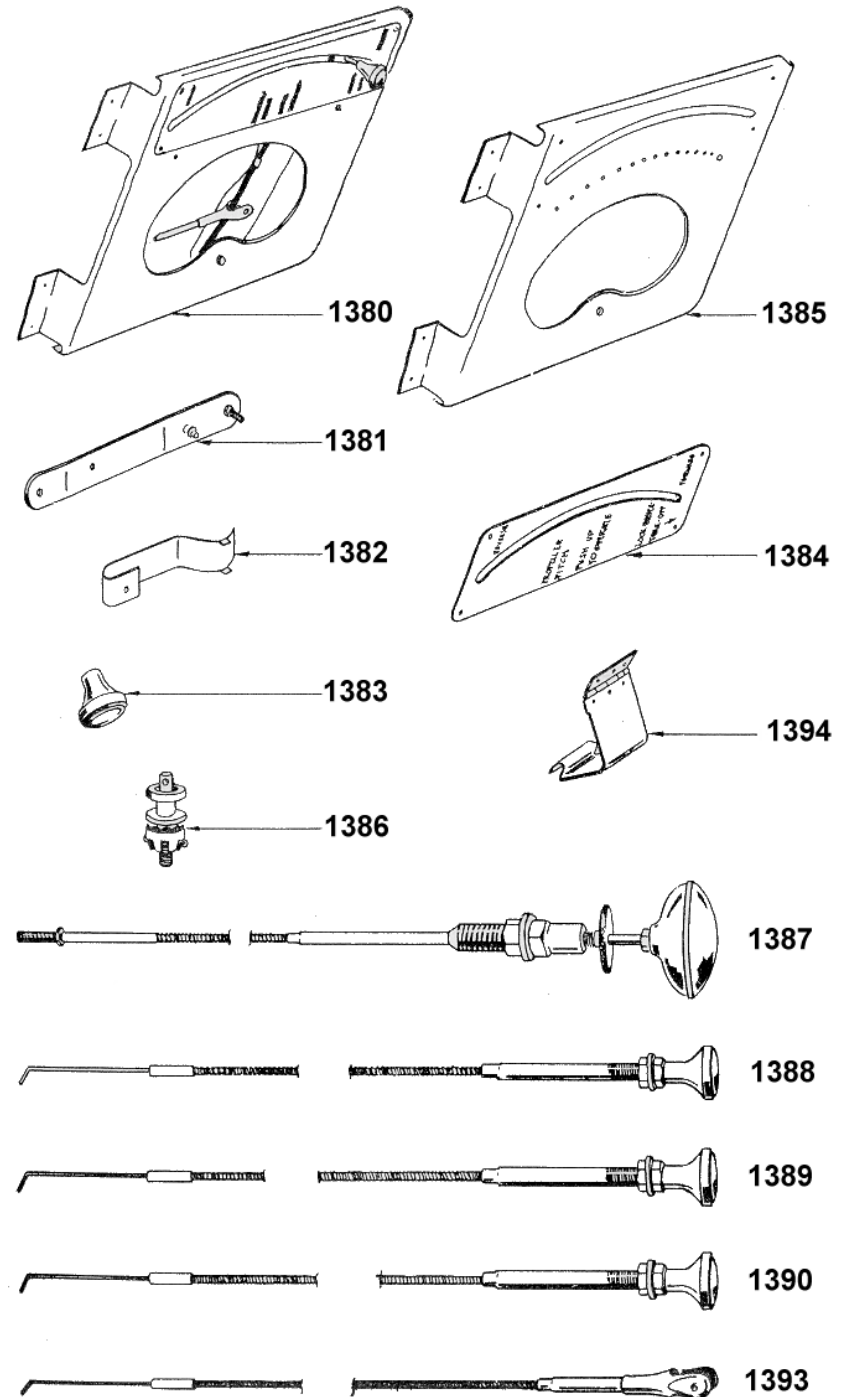

FUEL SYSTEM COMPONENTS

<u>NUMBER</u>	<u>PART NAME</u>
1250	<u>FUEL CELL INSTALLATION</u>
1251	<u>Fuel Cell</u>
1252	<u>Cover Assembly-Fuel Cell</u>
1253	<u>Screen Assembly-Fuel Cell</u>
1254	<u>Drain Assembly-Fuel Cell</u>
1256	<u>Washer-Fuel Drain</u>
1257	<u>Gasket-Fuel Drain Lower</u>
1261	<u>Gasket-Fuel Drain Upper</u>
1258	<u>Gasket-Fuel Cell</u>
1259	<u>Cock-Fuel Drain</u>
1260	<u>Bracket-Fuel Cell Hose</u>
1262	<u>Ring-Fuel Cell</u>
1263	<u>Hose-Fuel Cell Outlet</u>
1264	<u>Gasket-Fuel Measuring Tank Unit</u>
1267	<u>Tank Unit-Fuel Measuring</u>
1181	<u>PIPE ASSEMBLY-FUEL FILLER NECK WITH CAP</u>
1268	<u>GROMMET-FILLER NECK</u>
1269	<u>CAP ASSEMBLY-FILLER NECK</u>
1270	<u>HOSE-FILLER NECK PIPE CONNECTING</u>
1271	<u>STRAINER-FUEL FILLER NECK</u>
1249	<u>VALVE-FUEL CHECK (SHIPS 5 TO 125)</u>
1445	<u>VALVE-FUEL CHECK (SHIPS 126 AND UP)</u>
1147	<u>KIT, FUEL CHECK VALVE PACKING (NOT ILLUSTRATED)</u>
1428	<u>VALVE-FUEL SHUT-OFF</u>

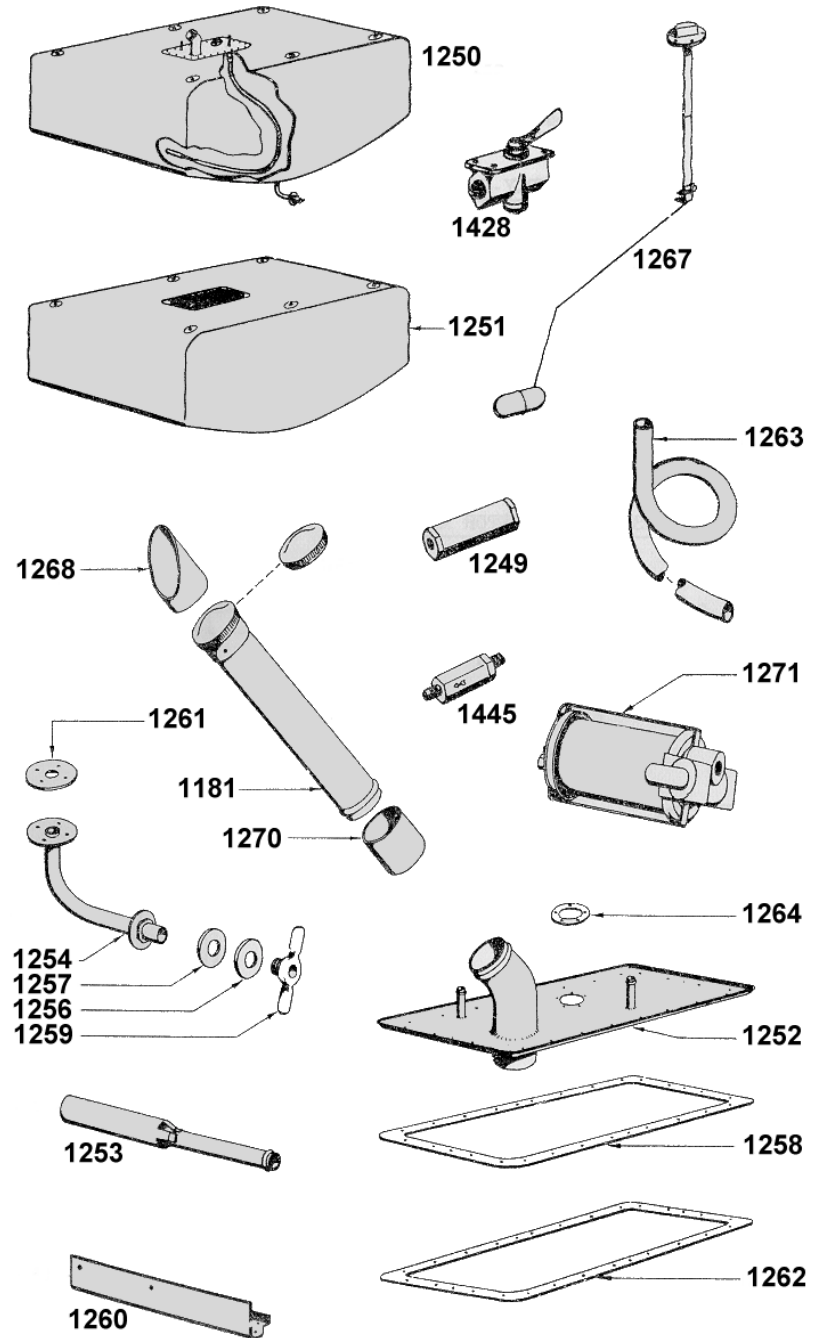

INDUCTION SYSTEM

<u>NUMBER</u>	<u>PART NAME</u>
1404	<u>CLAMP ASSEMBLY-EXHAUST SHROUD ENGINE FORWARD</u>
1405	<u>CLAMP ASSEMBLY-EXHAUST SHROUD ENGINE AFT</u>
1406	<u>SHROUD ASSEMBLY-EXHAUST</u>
1407	<u>DUCT ASSEMBLY-INDUCTION SYSTEM</u>
1408	<u>INTAKE-CARBURETOR AIR</u>
1409	<u>HOUSING-CARBURETOR AIR FILTER</u>
1410	<u>GASKET-CARBURETOR AIR INTAKE</u>
1411	<u>TUBE-CARBURETOR AIR INTAKE FLEXIBLE STEEL</u>
1412	<u>FILTER-AIR</u>

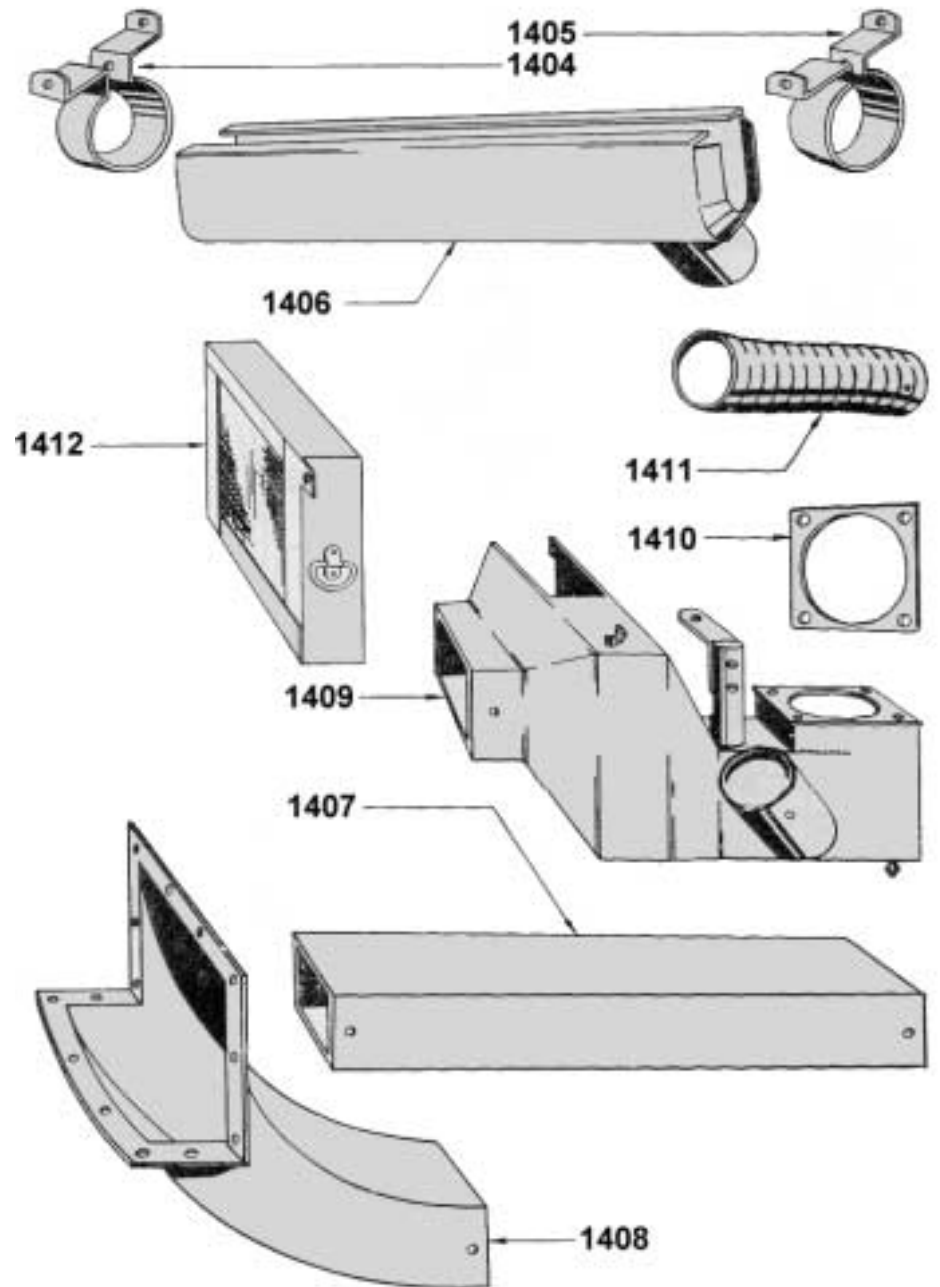

ENGINE AIR HOUSING

<u>NUMBER</u>	<u>PART NAME</u>
1370	<u>APRON ASSEMBLY-FRONT COWL</u>
1368	<u>BAFFLE-ENGINE REAR LEFT HAND</u>
1369	<u>BAFFLE-ENGINE REAR RIGHT HAND</u>
1366	<u>BAFFLE-ROCKER BOX LEFT HAND</u>
1367	<u>BAFFLE-ROCKER BOX RIGHT HAND</u>
1365	<u>BAFFLE ASSEMBLY-ENGINE CYLINDER LEFT HAND</u>
1364	<u>BAFFLE ASSEMBLY-ENGINE CYLINDER RIGHT HAND</u>
1363	<u>FAN HOUSING WITH BAFFLE</u>
1377	<u>TUBE ASSEMBLY-ENGINE BLAST LEFT HAND</u>
1378	<u>TUBE ASSEMBLY-ENGINE BLAST RIGHT HAND</u>

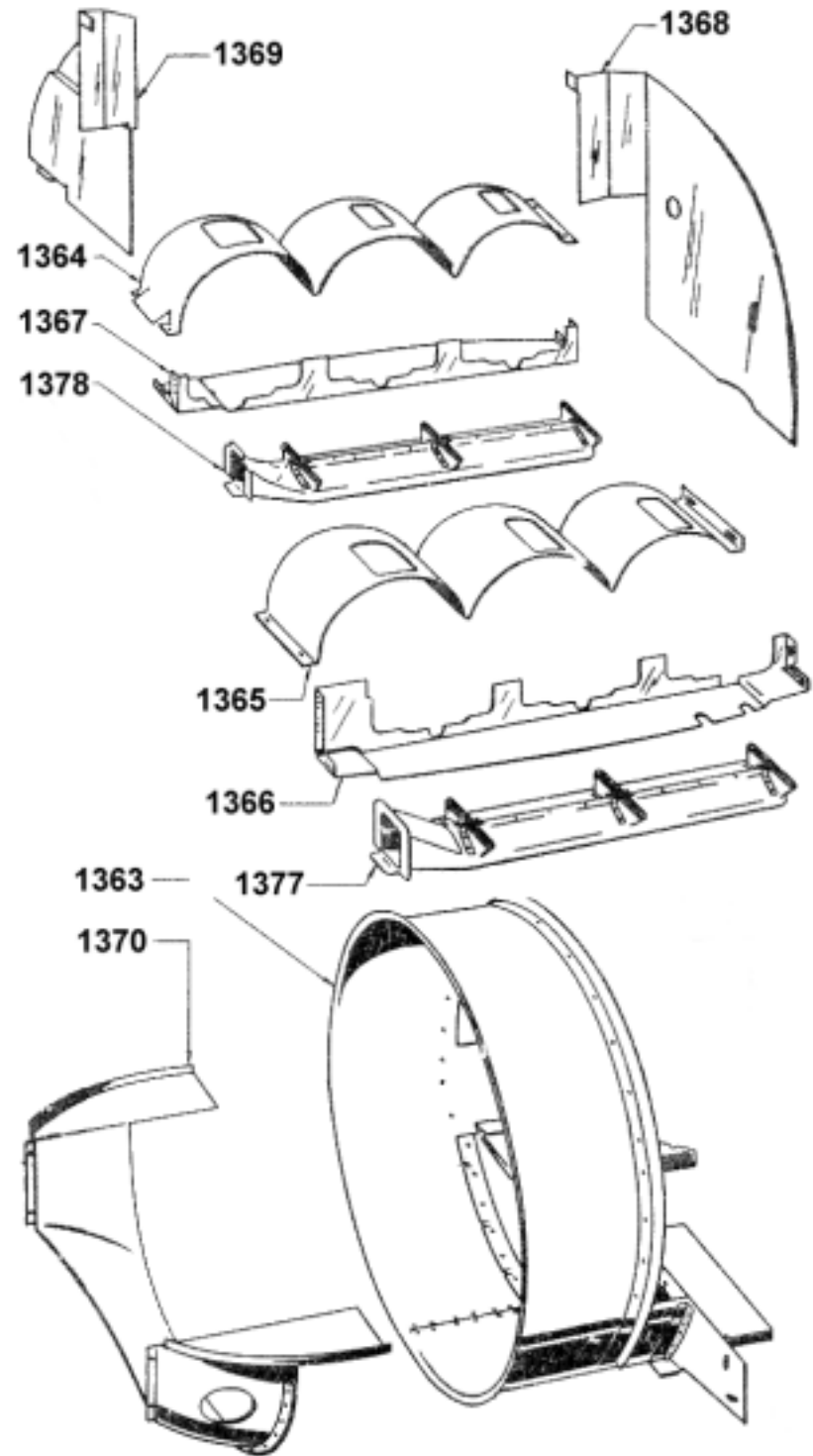

INSTRUMENT PANELS

<u>NUMBER</u>	<u>PART NAME</u>
1162	<u>PANEL ASSEMBLY-INSTRUMENT MOUNT (FOR USE WITH STEWART-WARNER ENGINE INSTRUMENT PANEL)</u>
1255	<u>Plug-Button-Instrument Panel Gage Provision</u>
1163	<u>Bearing Assembly-Instrument Panel Control Wheel Column</u>
1164	<u>PANEL ASSEMBLY-STANDARD FLIGHT INSTRUMENT</u>
1165	<u>PANEL ASSEMBLY-CROSS COUNTRY FLIGHT INSTRUMENT</u>
1167	<u>PANEL ASSEMBLY-ENGINE INSTRUMENT (STEWART-WARNER)</u>
1421	<u>PANEL ASSEMBLY-ENGINE INSTRUMENT (ELECTRIC AUTO-LITE)</u>
1423	<u>PANEL-DECORATIVE (CROSS COUNTRY FLIGHT INSTRUMENT GROUP)</u>
1422	<u>PANEL ASSEMBLY-INSTRUMENT MOUNT (FOR USE WITH ELECTRIC AUTO-LITE ENGINE INSTRUMENT PANEL)</u>
1255	<u>Plug-Button-Instrument Panel Gage Provision</u>
1163	<u>Bearing Assembly-Instrument Panel Control Wheel Column</u>

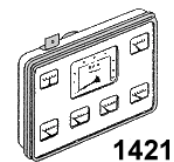
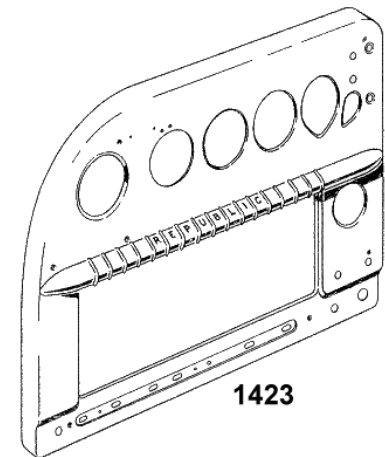
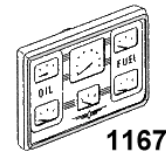
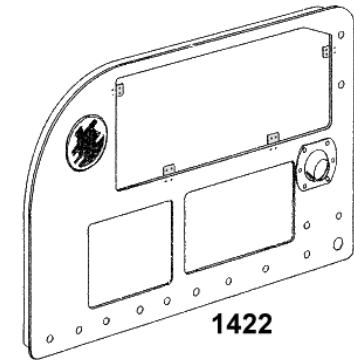
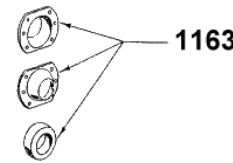
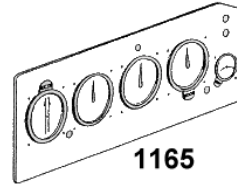
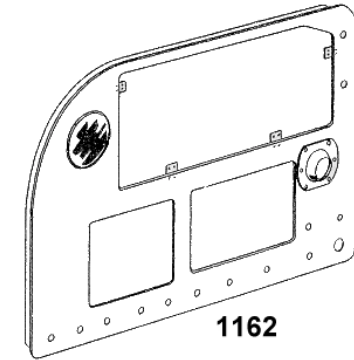
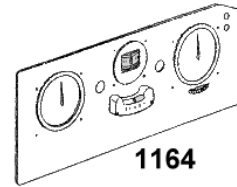

FLIGHT AND ENGINE INSTRUMENTS

<u>NUMBER</u>	<u>PART NAME</u>
1169	<u>ALTIMETER-(STANDARD FLIGHT INSTRUMENT GROUP)</u>
1173	<u>ALTIMETER-SENSITIVE (CROSS COUNTRY INSTRUMENT FLIGHT GROUP)</u>
1170	<u>INDICATOR-AIR SPEED (STANDARD FLIGHT INSTRUMENT GROUP)</u>
1174	<u>INDICATOR-AIR SPEED (CROSS COUNTRY FLIGHT INSTRUMENT GROUP)</u>
1171	<u>COMPASS-(STANDARD FLIGHT INSTRUMENT GROUP)</u>
1166	<u>COMPASS-(CROSS COUNTRY FLIGHT INSTRUMENT GROUP)</u>
1172	<u>INDICATOR-BALL BANK (STANDARD FLIGHT INSTRUMENT GROUP)</u>
1175	<u>INDICATOR-BANK AND TURN (CROSS COUNTRY FLIGHT INSTRUMENT GROUP)</u>
1176	<u>CLOCK-EIGHT DAY (CROSS COUNTRY FLIGHT INSTRUMENT GROUP)</u>
1233	<u>VALVE-SUCTION THROTTLING (CROSS COUNTRY FLIGHT INSTRUMENT GROUP)</u>
1159	<u>GAGE-OIL TEMPERATURE</u>
1160	<u>TACHOMETER-ENGINE</u>
1161	<u>Shaft-Engine Tachometer</u>
1177	<u>Drive-Engine Tachometer Right Angle</u>
1178	<u>GAGE-FUEL QUANTITY INDICATOR</u>
1179	<u>GAGE-MANIFOLD PRESSURE (FOR USE WITH VARIABLE PITCH REVERSIBLE PROPELLER)</u>
1183	<u>AMMETER</u>
1276	<u>GAGE-FUEL PRESSURE</u>
1277	<u>GAGE-OIL PRESSURE</u>
1283	<u>SOCKET ASSEMBLY-ENGINE INSTRUMENT PANEL LIGHT</u>

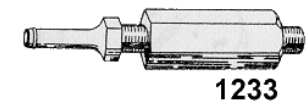
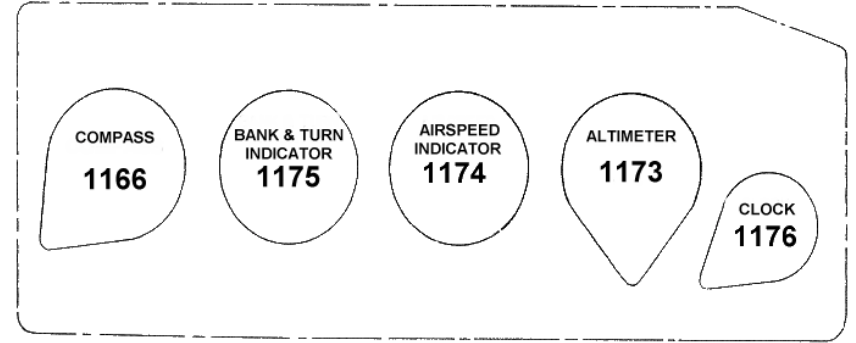
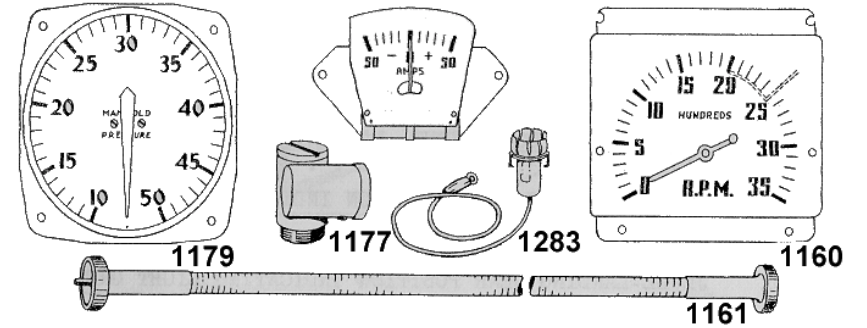
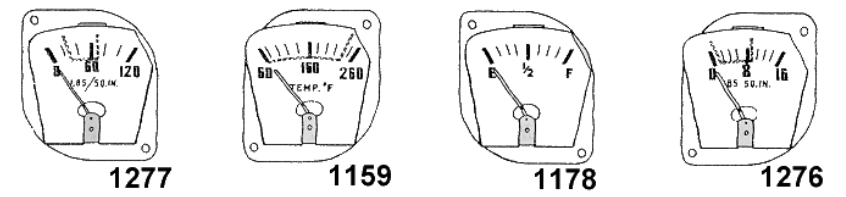
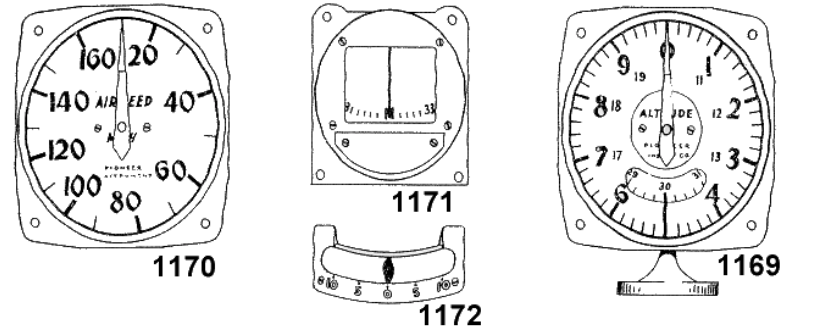

ELECTRICAL EQUIPMENT

<u>NUMBER</u>	<u>PART NAME</u>
1184	<u>BATTERY-ELECTRIC STORAGE</u>
1278	<u>CIRCUIT BREAKER-10 AMP</u>
1279	<u>CIRCUIT BREAKER-40 AMP</u>
1280	<u>LAMP BULB-INSTRUMENT PANEL OR LANDING GEAR POSITION INDICATING</u>
1281	<u>TRANSMITTER-OIL PRESSURE</u>
1282	<u>TRANSMITTER-FUEL PRESSURE LEFT HAND</u>
1282	<u>TRANSMITTER-FUEL PRESSURE RIGHT HAND</u>
1284	<u>TRANSMITTER-OIL TEMPERATURE</u>
1285	<u>CONTROL-BATTERY SWITCH PUSH-PULL</u>
1286	<u>SWITCH ASSEMBLY-BATTERY</u>
1287	<u>SWITCH-MASTER</u>
1288	<u>SWITCH-IGNITION AND STARTER BATTERY MAGNETO</u>
1290	<u>SWITCH ASSEMBLY-INSTRUMENT LIGHT</u>
1291	<u>SWITCH-FUEL PRESSURE SELECTOR</u>
1292	<u>SWITCH-CABIN DOME LIGHT, NAVIGATION LIGHT, ANCHOR LIGHT</u>
1293	<u>SWITCH-LANDING GEAR POSITION INDICATING LIGHT</u>
1294	<u>JEWEL-LANDING GEAR POSITION INDICATING LIGHT RED</u>
1301	<u>JEWEL-LANDING GEAR POSITION INDICATING LIGHT GREEN</u>
1295	<u>DISCONNECT-ELECTRICAL SYSTEM QUICK</u>
1296	<u>LIGHT-CABIN DOME</u>
1298	<u>HOLD-DOWN BATTERY</u>
1299	<u>BOLT-BATTERY HOLD-DOWN</u>
1300	<u>CABLE-BATTERY HOLD-DOWN</u>
1330	<u>CABLE-BATTERY TO BATTERY SWITCH ELECTRIC</u>
1331	<u>CABLE- ENGINE TO GROUND ELECTRIC</u>
1332	<u>HARNESS-CABIN ELECTRIC WIRING</u>
1333	<u>HARNESS-ENGINE ELECTRIC WIRING</u>

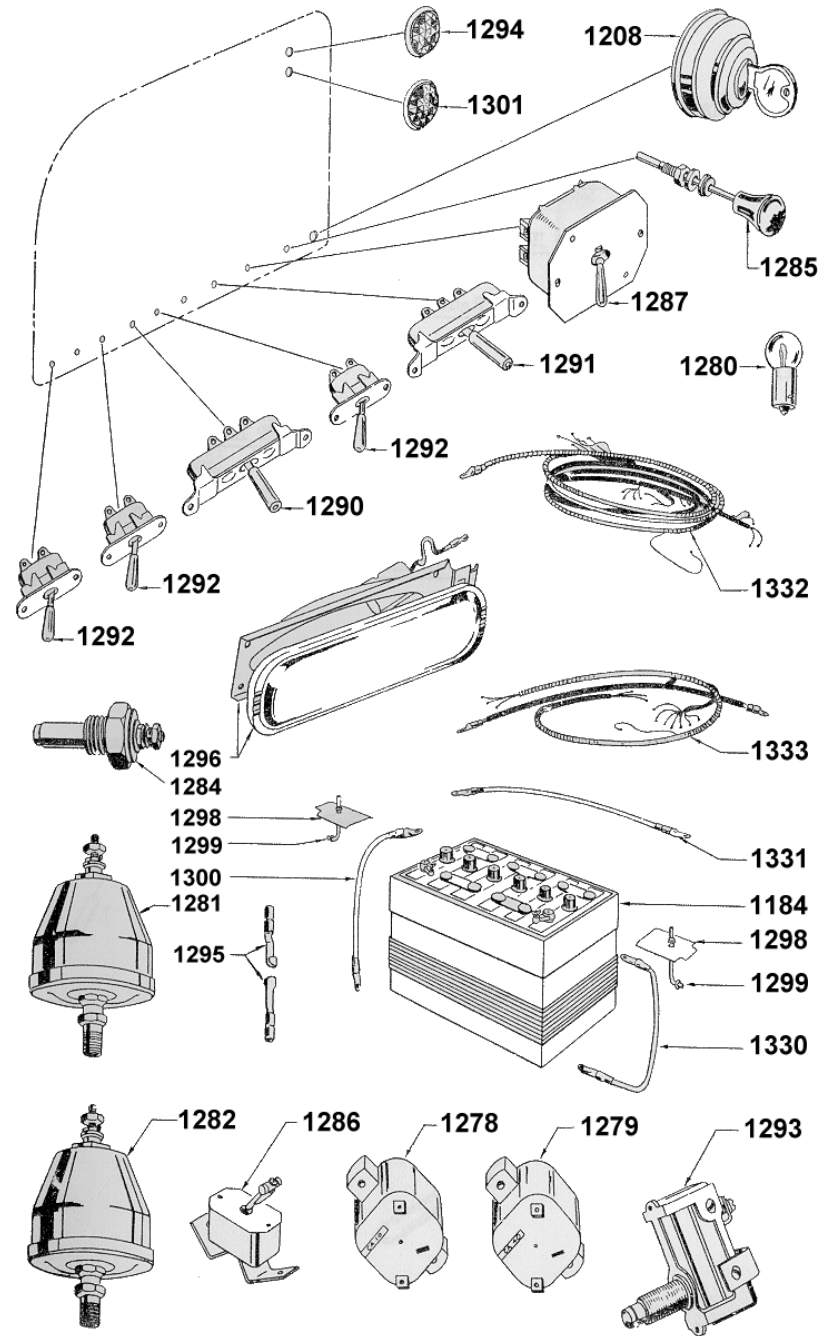

RADIO

<u>NUMBER</u>	<u>PART NAME</u>
1180	<u>RADIO SET (CA-4, HALLICRAFTER)</u>
1447	<u>Radio Head Set</u>
1448	<u>Microphone Radio</u>
1185	<u>ANTENNA ASSEMBLY-RADIO</u>
1186	<u>ANCHOR ASSEMBLY-WING ANTENNA LEFT HAND</u>
1431	<u>ANCHOR ASSEMBLY-WING ANTENNA RIGHT HAND</u>
1187	<u>ANCHOR ASSEMBLY-FIN ANTENNA</u>

